

# Chapter 1: Build and Test a Standard House

## *Introduction*

The overall goal of this engineering project is to design a house that is energy efficient to keep a steady inside temperature and can be heated by the sun. You will be working with a model rather than a full-sized house, but the principles are the same. By the end of this project, you will understand the heat transfer basics and design principles that you would need to design an energy-efficient house.

Before you start on your own house design, you will build and test a pre-designed “standard house” to familiarize yourselves with the materials, building methods, and measurements you will use to evaluate your design.

This is called a standard house because everyone will start by building the same one. Also, it will be the standard against which you can compare the performance of your own design later in this project.

The standard house meets the same criteria that you will follow when you build your own design. Your teacher will provide a cutout, which you can trace onto card stock, cut out, fold, and tape together. The windows can be made out of clear acetate.

This project uses a standard procedure for measuring the thermal performance of a house. For the house to lose heat, there must be a temperature difference. The interior of the house must be warmer than the outside. Since you can't cool down your classroom to 0 °C, you will warm up your house to 10 °C above room temperature. This is done with a heater light bulb inside the standard house.

As with a real house, what matters is how long the furnace must be on to keep the house warm. The more it's on, the more energy is used per day and the greater your heating bill. To imitate this situation, you will record what percentage of time the heater light bulb must be on to keep the house at 10° C above room temperature.

Finally, you will perform the same test, but with a bright light shining on the house, imitating sunshine. You can then tell how much your energy bill is reduced by “solar heating.”

---

Build a model house and measure how much energy is needed to keep it warm.

---

## Tools & materials

- Computer
- Logger Lite
- One temperature sensor
- USB Flash drive
- Full-scale cutout of standard house and base for tracing
- Metal ruler (cm)
- Scissors
- Safety utility cutter
- Pencils
- Cardstock sheet, 56 x 71 cm (22 x 28 in)
- Cardboard surface to cut on
- Acetate sheets for windows
- Clear tape
- One 40 W heater light bulb in a socket with an inline switch, covered with aluminum foil
- One sun light bulb in a gooseneck fixture

## Standard House Description

- The standard house has a floor area of  $400 \text{ cm}^2$  (16 x 24 cm) .
- The window is on the south side that faces the sun, and its area is  $120 \text{ cm}^2$ .
- There is enough room inside for the light bulb (15 cm high) and its base. There is a 12 cm diameter hole in the floor for the heater light bulb.
- Materials for the initial design are limited to cardstock, clear acetate, and tape.
- The house sits on a base, larger than the house. The base is labeled with the directions north, south, east, and west for testing purposes, so that you can picture the house with a real orientation with respect to the sun\*.
- One sensor is inserted through the wall of the house.

\* Note that this workbook is written for a climate at about  $40^\circ$  north latitude that has warm summers and cold winters. Other climates may have quite different design issues, and the sun's path changes in other latitudes.

# Building Instructions

1. Trace the two pieces of the standard house on a piece of cardstock, using the full-scale template provided by the teacher. Note how they must be arranged to fit on one sheet. Be sure to mark the locations for the sensor as shown on the template.

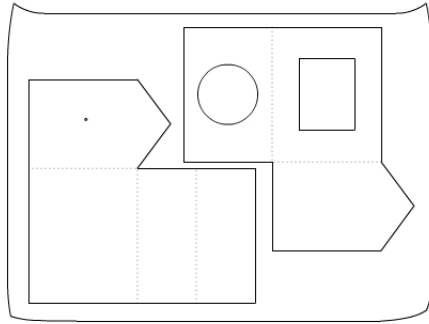

2. Cut out the two pieces, using scissors.
3. Use a sharp pencil to make a hole for putting a temperature sensor in a pre-marked spot. The hole is 10 cm above the floor.
4. Cut out the window and tape a piece of acetate over it on the side of the cardstock that will be inside the house.
5. Cut a circle out of the bottom of the house, as in the template, so that the heater light bulb can fit in. (The circle happens to be the same size as a CD.)
6. Fold the cardboard along the dashed lines. Use the edge of a table to make straight folds.

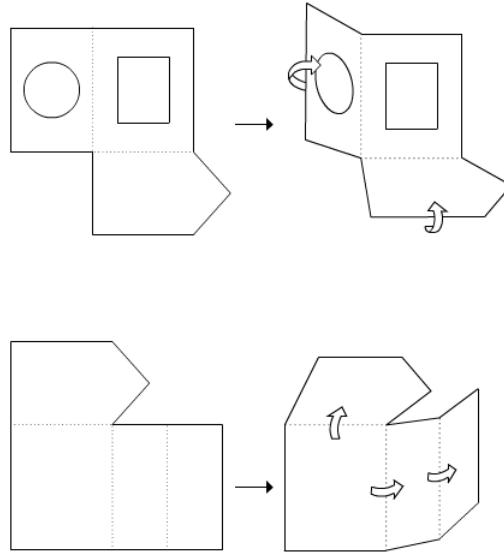

7. Tape the edges together.
8. The teacher will supply a piece for the base of the house (1/4 of a cardstock sheet, about 28 x 35.5 cm).
9. Label the base with directions: North, South, East, West.
10. Place the bulb with foil on the base.
11. Feed the power cord of the bulb through one corner of the house, as in the picture below. Then tape the joints closed around it.

12. Place your house and bulb on the base so that the window faces south and the bulb fits through the hole in the base of the house.
13. Write your team name on the house.
14. Your house will look similar to the house pictured below.

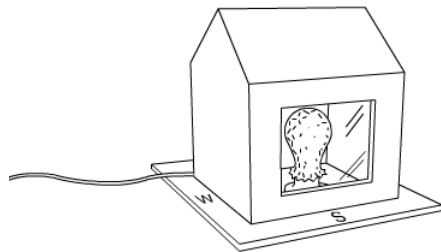
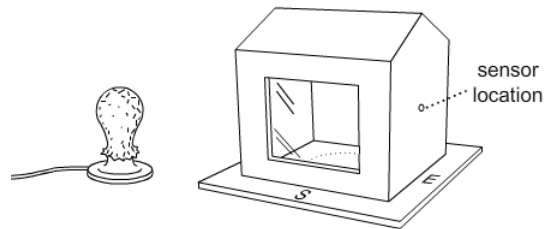

*Note the power cord coming out of one corner of the house.*

## *Power and energy*

Energy is a special quality in science and engineering. It has many forms – thermal, kinetic, potential, chemical, electrical, nuclear, and radiation. It can change form, but the total amount of it is constant. In other words, energy is not created or destroyed; it just changes form. This principle, called the Conservation of Energy, is central to understanding heat flow.

In simple terms, energy is how much, and power is how fast you use it. A car has a certain amount of energy when going 60 mph. A more powerful engine can get up to that speed more quickly. Power (P) determines how fast the heat flows or changes. It is measured in watts, which is the same as joules/second.

$$P = Q/t$$

**Watts (W) = joules (J) / seconds (s)**

We can also say that the amount of heat energy is the power multiplied by the time.

$$Q = Pt$$

**Joules (J) = watts (W) \* seconds (s)**

For example, the power output of a 40 W light bulb is 40 watts. If the bulb is on for one minute it produces 2400 Joules of energy.

$$2400 \text{ J} = (40 \text{ J / s}) (60 \text{ s})$$

In everyday practice, electrical energy is expressed in kilowatt-hours rather than joules.

$$1 \text{ J (1 W-s/J) (1 hr/3600 s) (1 kW/1000 W) = } 27.8 \times 10^{-6} \text{ kWh}$$

$$1 \text{ J} = 27.8 \times 10^{-6} \text{ kWh}$$

$$1 \text{ kWh} = 3,600,000 \text{ J}$$

As this shows, kilowatt-hours are a more convenient unit because Joules are so small. Also, it's easier to work with hours than with seconds.

What is the power output of a 100 W bulb?

How much energy does a 100 W bulb use in 24 hr?

How much energy (in kilowatt-hours = 1000 watt-hours) would the bulb use if left on for a year?

How much energy would you save if you replaced the bulb with a 20 W fluorescent, which has about the same light output?

How much money would you save if electricity costs \$0.15/kWh?

## Celsius vs. Fahrenheit (optional)

Note to American students: You will use the Celsius scale for these measurements, so here's a quick exercise to remind you about Celsius vs. Fahrenheit. Fill in Table 1.

$$C = 5/9(F - 32)$$

or

$$F = (9/5)C + 32$$

Celsius vs. Fahrenheit		
	Temperature in °C	Temperature in °F
Water freezes		
Water boils		
Room temperature	20	
A hot day		100

For example, suppose the room temperature is 20 °C. The target temperature for the warmed-up house will be 10 °C higher. What will these temperatures be as measured on the Fahrenheit scale? Fill in Table 2.

Experimental conditions		
	Temperature in °C	Temperature in °F
Room temperature	20	
Target house temperature	$20 + 10 = 30$	
Outdoor temperature if it were 10 °C below room temperature	$20 - 10 = 10$	

The last calculation is to show that our experimental conditions have the same temperature difference as a house kept at 20 °C when the outdoor temperature is 10 °C (50 °F). It's a cold day, but not freezing.

# Warm up the house

## Introduction

Your goal is to warm up your house to 10 °C greater than the air around it. To do this, you will raise the house to the target temperature using the heater light bulb.

As you perform the following steps you will look at the graph generated by Vernier Logger Lite, which will record the time and temperature automatically and represent them graphically.

## Quick Start for Logger Lite

Open the Logger Lite file (.gml) that goes with the experiment. (Note: the file name always ends with .gml.) It will recognize the sensors that are attached to the computer. It will have the right settings, but you can change them under "Experiment/data collection."

Use the "collect" button to collect data.

If you have two sensors, touch one very briefly to find out which is which.

Use the "scale" icon to set the size of the graph to match the data.

Drag the axes up and down to expand or shrink the scale.

If the graph stops because the time ends, you can continue by choosing "append to latest" rather than "erase and continue" when you try to collect.

To save a dataset and add another one to the same graph, click on the "store" icon and then start collecting. The previous dataset will change to a thin line.

Use the "analyze" button to scan the graph for specific values, which are shown in the data table to the left.

When you save your file, it will be saved as the file you opened. If you want to save another dataset, save it with a different name.

---

How long does it take to heat up your house?

---

## Tools & materials

- Standard house
- One temperature sensor
- Computer
- USB Flash drive
- Logger Lite for plotting temperature
- One 40 W heater light bulb in a socket with an inline switch, covered with foil

### Set up the sensors

1. Connect one temperature sensor to your computer.
2. Open the Logger Lite file that goes with this experiment: *std house warm up.gmbl*. It will open Logger Lite with the proper settings for this experiment.
3. Touch the end of the sensor to make sure it works. You should see the graph go up.
4. Measure the room temperature and record it in the table below. We will assume it stays reasonably constant throughout the experiment.
5. Experiment with changing the range of the Y-axis, which is done by dragging the mouse along the Y-axis. You can expand it to see very small changes!
6. Calculate your target temperature: about 10 °C above room temperature (round it up to a whole number). Record the target temperature in the table below.

## Procedure & data collection

1. Cut a 3x3 cm square of cardstock and tape the sensor to the center of it 3 cm from its tip. Fold the sensor 90° so that it is perpendicular to the card and is 3 cm long.

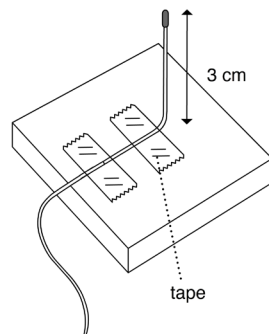

2. Insert the temperature sensor in the hole you made in the middle of the wall of the standard house. The sensor must be pushed through the wall so that it is perpendicular to the wall. Make sure it is not touching the wall. Tape the card to the outside of the house to keep the sensor in place.

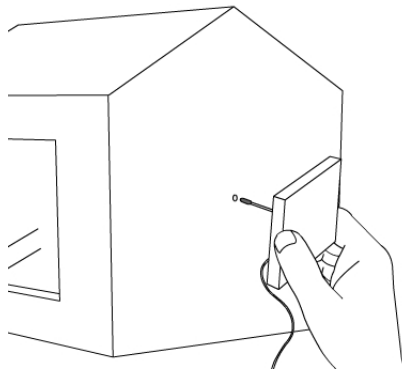

2. Start collecting data by clicking the "collect" button..
3. Wait 10 seconds.
4. Switch the heater light bulb on. Record the time in the table below.
5. When the sensor reaches the target temperature, switch the bulb off. Record the time in the table below.
6. The graph produced by Logger Lite should look similar to the graph below. It may be helpful to annotate your graph with similar labels.

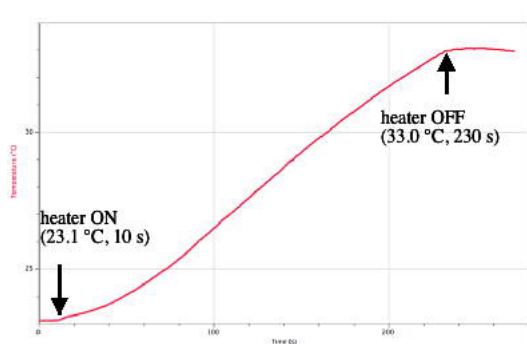

7. Save the Logger Lite file.

Warming up the house	
Room temperature: _____ °C	
Target temperature: _____ °C	
Heater is turned ON at _____ s	Heater is turned OFF at _____ s
Total time heat is ON: _____ s	

## *Analysis*

If the input of heat is constant throughout the experiment, why is the graph steeper at the beginning and less steep as the temperature rises?

The Joule, a unit of energy, is equal to a watt-second. How many Joules were needed to heat up your house? Show your calculation.

If you left the heater on for a long time, what would happen to the temperature in the house?

---

What is the power requirement to keep a house warm on a cold day?

---

## Keep the house warm

### *Introduction*

This project uses a standard procedure for measuring the thermal performance of a house. For the house to lose heat, there must be a temperature difference. The interior of the house must be warmer than the outside. Since you can't cool down your classroom to 0 °C, you will warm up your house to 10 °C above room temperature. This is done with a heater light bulb inside the standard house.

As with a real house, what matters is how long the furnace must be on to keep the house warm. The more it's on, the more energy is used per day and the greater your heating bill. To imitate this situation, you will record what percentage of time the heater light bulb is on.

Your goal is to measure how much power it takes to keep your house 10 °C warmer than the air around it. To do this, you will:

- Turn the heater on and off so that the temperature stays within 0.2 °C of the target temperature.
- Record the times when the heater is turned on and off.
- Calculate what percentage of time the heater has to be on to keep the house warm.
- Multiply that percentage by the heater power (40 Watts) to get the average power supplied to the house.

## Collect data

1. Open the Logger Lite file that goes with this experiment:  
*std house keep warm.gmbl*
2. Assume that room temperature has not changed (see page 10). Calculate the target temperature (room temperature + 10) and enter it in the table below.
3. Turn the heater on.
4. Start collecting data when the sensor is a few degrees below the target temperature.

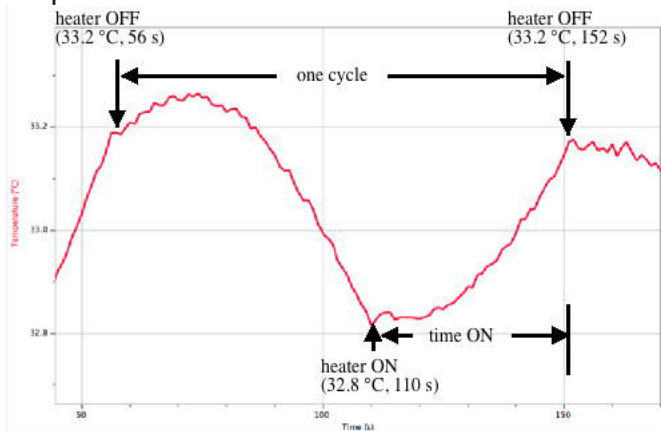

5. Refer to the sample graph above, which should look roughly like yours. When the sensor reaches 0.2 °C above the target temperature, switch the heater OFF and record the time in the table below (A). Note that the data table in Logger Lite makes it easy to note the current time while data is being collected.

Note: the temperature may continue to rise for a time. That's OK.

6. When the sensor drops to 0.2 °C below the target temperature, switch the heater ON and record the time in the table below (B).

Note: the temperature may continue to fall for a time. That's OK.

7. When the sensor again reaches 0.2 °C above the target temperature, switch the heater OFF and record the time in the table below (C).
8. Stop collecting data.
9. Click the "scale" icon to fit the graph to your data.
10. Save the Logger Lite file.

11. Calculate the average power requirement to keep the house warm by filling out the rest of the table below.

House heating test	
Room temperature:	_____ °C
Target temperature:	_____ °C
Upper limit (target temperature + 0.2):	_____ °C
Lower limit (target temperature - 0.2):	_____ °C
Event	Time (from data table)
A. Turn heater OFF at upper limit (point A)	
B. Turn heater ON at lower limit (point B)	
C. Turn heater OFF at upper limit (point C)	
D. Total cycle time (C - A)	
E. Total time ON (C - B)	
F. proportion of time the heater is on (C - B) / (C - A)	
G. Average power requirement (40 W * proportion of time heater is on)	_____ W

### How to calculate the power requirement (Row G)

You used the energy provided by the heater to heat up your house and maintain it at your target temperature. The bulb you used as a heater has a power of 40W. This means that it releases 40 joules of energy per second. But since it wasn't on all the time, the house used less than 40 W to stay warm. The average power requirement of your house is:

$$\text{Power requirement} = 40 \text{ W} * \text{time on} / \text{total time}$$

Note that the total time should be a full cycle, from OFF to ON to OFF again.

The steps of the calculation are set out in the table above.

## *Analysis*

In your own words, explain the difference between energy and power.

Which did you measure in this experiment, power or energy?

What are the units for energy? What are the units for power?

The light bulb in this test house is supposed to model the furnace or boiler in your house. Describe how turning the light bulb on and off is similar to a thermostat in your house.

How do you think you could reduce the power needed to maintain the house temperature in this model? Explain what you would do and how it would help.

## Connection to buildings (optional)

### Background

The light bulb in the standard house is like the furnace or boiler in your house. It has a fixed output and is on part of the time. Heating units are sized so that they would be on all of the time only on the coldest days, when there would be the greatest temperature differences between inside and outside, and hence the greatest rate of heat loss. If you improved the energy efficiency of your house, the heater would be on less time and use less total energy over the year.

Your house has a thermostat, which does exactly what you did by hand in the experiment: it turns the heater on when the house temperature is below the set temperature, and off when the temperature rises above the set temperature. If you graphed the temperature in your house, it would be a wavy line like the graph in this experiment.

In a real house, the yearly energy requirement would be calculated by looking at the energy bill (for example, 400 gallons of oil multiplied by 130,000 BTU/gallon = 52 million BTU = 15,200 kWh).

Note: in the USA, both kilowatt-hours (kWh) and British Thermal Units (BTU) are in common use as heating energy units. If you want to interpret your energy bill and compare electrical energy to oil or gas energy, you will need to convert from one to the other.

**1 kWh = 3412 BTU**

Look up your actual heating energy use, following the steps below.

1. Measure the approximate floor area of your own house. One way is to measure on the outside and reduce the house plan to simple rectangles. You can measure in feet and then convert from square feet to square meters, if that's easier.

**1 m<sup>2</sup> = 10.8 ft<sup>2</sup>**

Your house area in m<sup>2</sup>: \_\_\_\_\_

2. Convert the results to kWh.

Figure out the amount of energy you use for heating. You probably use electricity, oil, or natural gas.

Make use of the following *approximate* conversion factors:

**1 kWh = 3400 BTU**

**For oil, 1 gallon = 120,000 BTU (allowing for a boiler efficiency of 85%)**

**For natural gas, 1 Therm = 100,000 BTU**

Your heating energy use in gallons (oil) or therms (gas) \_\_\_\_\_

Your annual heating energy use in kWh: \_\_\_\_\_

If your boiler heats domestic hot water as well as the house, subtract the average monthly summer use from each winter month (about six months in all) to obtain just the heating energy. If heating and hot water are separate, you can skip this step.

Your average monthly hot water energy use in kWh: \_\_\_\_\_

Your hot water energy use for 12 months in kWh: \_\_\_\_\_

Your annual heating minus hot water energy use in kWh: \_\_\_\_\_

The energy use per square meter per year for your house, in kilowatt-hours per m<sup>2</sup>: \_\_\_\_\_

## Solar Heating Test

---

How does energy provided by the sun reduce the house heating requirement?

---

### *Introduction*

During the last session you built your house and heated it using a heater light bulb. That situation mirrors the nighttime when there is no sunlight.

Now you will add a very bright light bulb (300 W) outside as the “sun.” Its position will be roughly that of the sun at noon in winter in the northern United States (40° N). You will use a single temperature sensor to measure the house temperature.

You will turn the heater on and off, but leave the sun on all the time. This will simulate a sunny day with light from the 300 W bulb providing “solar energy.”

## Set up the sensor

1. Insert the temperature sensor in the hole at the top of your house.
2. Connect the temperature sensor to your computer.
3. Open the Logger Lite file that goes with this experiment:  
*std house solar heating.gmbl*
4. Logger Lite will display the temperature. Record the room temperature in the table below.
5. Calculate the target temperature (room temperature + 10) and enter it in the table below.
6. Set up the gooseneck lamp with a sun light bulb in it, due south of the building.
7. Place the sun angel template so the corner is in the center of the window.
8. Aim the tip of the light bulb along the "winter test angle" line on the template (see figure below).

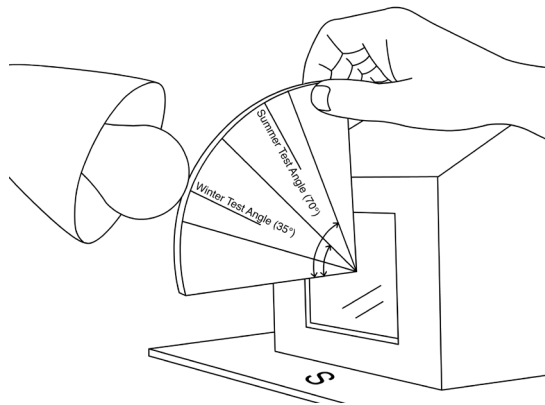

## Tools & materials

- Standard house
- One temperature sensor
- Computer
- Logger Lite
- USB Flash drive
- One 40 W heater light bulb
- One sun light bulb in a gooseneck desk lamp
- Template for measuring "sun's" angle

## Procedure - Collect data

1. Switch the heater light bulb AND the sun light bulb on.

NOTE: The 300 W bulb is very hot. Be careful not to touch it, and wait until it cools down to move or store it. Turn it off except while doing the experiment.

2. Start collecting data when the sensor is a few degrees below the target temperature.
3. When the sensor reaches  $0.2\text{ }^{\circ}\text{C}$  above the target temperature, switch the heater OFF and record the time in the table below (A). Leave the sun on.
4. When the sensor reaches  $0.2\text{ }^{\circ}\text{C}$  below the target temperature, turn the heater ON. Record the time in the table below (B).
5. When the sensor again reaches  $0.2\text{ }^{\circ}\text{C}$  above the target temperature, switch the heater OFF and record the time in the table below (C).
6. Stop collecting data.
7. Click the "scale" icon to fit the graph to your data.
8. Save the Logger Lite file.
9. Calculate the power requirement to keep the house warm by filling out the rest of the table below.

### Solar heating test

Note: Sun is ON for the whole experiment.

Room temperature: \_\_\_\_\_°C

Target temperature: \_\_\_\_\_°C

Upper limit (target temperature + 0.2): \_\_\_\_\_°C

Lower limit (target temperature – 0.2): \_\_\_\_\_°C

Event	Time in seconds (from data table)
A. Turn heater OFF at upper limit	
B. Turn heater ON at lower limit	
C. Turn heater OFF at upper limit	
D. Total cycle time (C - A)	
E. Total time ON (C - B)	
F. proportion of time the heater is on (C - B) / (C - A)	
G. Power requirement (40 W * proportion of time heater is on)	_____ W
H. Average power requirement without the sun (from previous experiment)	_____ W
I. Power supplied by the sun	_____ W

## Results

Report your results. What is the solar contribution to house heating, in watts and as a percentage of the power requirement?

## Analysis

In a real situation, there might be strong sunshine for six hours a day, on average, out of twenty-four. On the other hand, the light would be much more intense than a 300 W light bulb. What might the solar contribution be in that case?

## Instructions

1. Make a claim. Answer the first question with one or two sentences only.
2. For the second question, use evidence, data, examples, results, or descriptions from your experiment(s) and/or model-based activity.
3. For the third question, apply what you learned from your experiment and model-based activities to support the claim you made.

**Claim:** Describe a design change that could increase the house's ability to take advantage of energy from the sun.

**Evidence:** What did your experiments show you about the solar affect on energy usage for the house?

**Reasoning:** How do the results of your experiments support your claim above?

## Connection to buildings (optional)

### Explore

Think about your own house and the possibility of using sunshine for heating it.

- a. How many south-facing windows does your house have? Measure the area of each and add them up.

\_\_\_\_\_ south-facing glass m<sup>2</sup>

- b. Previously you measured the floor area of your house. Calculate the ratio of south-facing glass to floor area.

glass area / floor area \_\_\_\_\_

- c. How good is your south-facing exposure? Are there trees or other buildings that cast shade for part of the day?

- d. Could you add more south-facing windows?

- e. What would you do to increase heat gain during sunny periods, but minimize heat loss at night?

# Chapter 2: Heat Transfer

## Introduction

As warm-blooded animals, we all care about heat and temperature! Our survival, not to mention comfort, depends on keeping our bodies at a constant temperature, despite huge changes in the environment. The focus here is on buildings, but the same principles apply to our bodies. Every day, we experience conduction (heat transfer through clothes), convection (moving air or water), and radiation (especially sunshine), which are the basic ways that heat is transferred.

In buildings, temperature is a key part of comfort. The more efficiently it can be kept at a comfortable temperature, the better, since a significant part of the nation's energy budget is devoted to the heating and cooling of buildings.

Heat transfer is an important aspect of green building. Heat transfers from warmer to cooler things. This equalizing of temperature occurs in three ways:

*Conduction:* the transfer of heat through a solid material. Heat is transferred directly in and through the substance. Loss of heat through blankets or transfer of heat through the handle of a hot frying pan to your hand are examples of conduction.

*Convection:* the transfer of heat by the movement of fluids such as air or water. Hot air rising up a chimney or hot water circulating in a pot on the stove are examples of convection.

*Radiation:* energy that travels directly through space as electromagnetic waves. It does not require matter for transmission. Most radiation associated with heat is either visible light or infrared radiation, which is not visible. The warmth from a fire is mostly infrared.

In this unit you will explore each means of heat transfer and apply this knowledge to energy efficient house design.

---

What is heat? How is it stored?

---

# Heat transfer and thermal equilibrium

Thermal energy is the total kinetic energy of the molecules of a substance. It is the energy needed to raise the temperature of the substance from absolute zero, which is  $-273$  degrees Celsius or  $0$  Kelvin to its actual temperature. It is measured in Joules, kilojoules, or other units of energy.

Heat ( $Q$ ) is the thermal energy that can be transferred between two systems by virtue of a temperature difference. It is much smaller than the total thermal energy because normal temperature differences are small. For example, when a hot drink cools down, it loses thermal energy or heat to the surroundings due to a difference in temperature. When it reaches room temperature it still has lots of thermal energy, but no more heat is available because there is no temperature difference.

Temperature measures the average kinetic energy of the molecules of a substance. Kinetic energy includes all of their motion: vibration, translation, and rotation. Molecules are always moving except at absolute zero, which is defined as the temperature at which all motion stops.

Heat flows from a hotter to a colder body until the two are in equilibrium at the same temperature. The total amount of heat remains the same, unless heat is lost or gained from the system.

# Heat storage

The heat stored in a material, called its heat capacity or thermal mass, is

$$Q = c_p m \Delta T$$

**Q** = heat (kJ)

**$c_p$**  = specific heat (kJ/kg K)

**m** = mass (kg)

**$\Delta T$**  = change in temperature of the material (degrees Kelvin - K, or degrees Celsius - °C)

Expressed in words, this equation says that the heat stored in a material depends on its heat capacity per unit mass (different for different materials), its mass (how much of it there is), and the change in temperature of the object. The symbol ( $\Delta T$ ) means “change in temperature.” It could also be written as ( $T_2 - T_1$ ).

Note the units for  $c_p$  (kJ/kg K). Specific heat is the kilojoules of energy that it takes to raise one kilogram of a material one degree Kelvin (which is the same as one degree Celsius).

Note that heat capacity or thermal mass ( $c_p m$ ) is the total heat per degree of temperature change stored in an object.

Different materials can store different amounts of heat because they have different specific heats. For example, for a given change in temperature, the same amount of heat is stored in a roomful of air, a cubic foot of bricks, or a gallon of water.

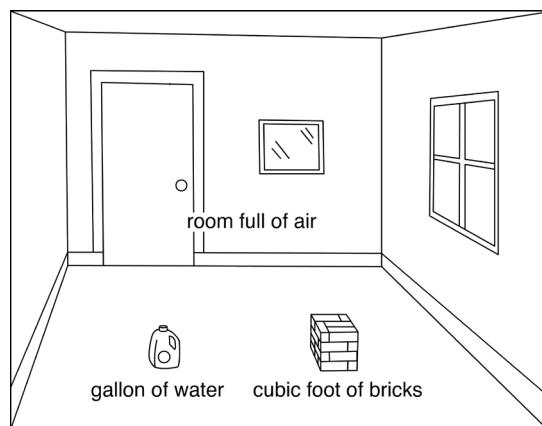

Air doesn't hold much heat, and most heat storage in buildings is in the solid materials – plaster walls, concrete floors, etc. Very little of it is in the air, which is quick to heat up, and quick to cool down.

Water has a very high heat capacity, that is, it takes a lot of energy to change the temperature of water a small amount, compared to many other materials. This is very significant in both natural and man-made systems. For example, much more heat is stored in the world's oceans than in its atmosphere, which is important when thinking about climate change. As another example, a much smaller volume of water is needed than air to transport heat from one place to another – say from the furnace to the rooms of a house.

# Investigating heat storage

Heat flows from a hotter to a colder body until the two are in thermal equilibrium at the same temperature. The total amount of heat remains the same, unless heat is lost from the system or gained from the outside. This is the principle of Conservation of Energy.

This principle can be used to measure the amount of heat stored in a material. If heat is allowed to flow between two objects at different temperatures, the heat gained by one object (A) is equal to the heat lost by the other one (B).

$$(c_p m \Delta T)_A + (c_p m \Delta T)_B = 0$$

$$(c_p m \Delta T)_A = -(c_p m \Delta T)_B$$

The following set of models allows you to use this principle to explore the factors that affect heat storage.

## 1A: Measuring heat storage

---

**Energy2D**

You touch a cup of hot coffee to feel how much heat it contains. What you feel is the amount of heat flowed into your hand. Touching a hot object with a cold object and checking how much the cold object warms up is a method to measure how much heat is originally stored in the hot object.

The first model you can try has two identical rectangular objects that are in contact. They have different initial temperatures that can be adjusted. Open Model 1A and follow the instructions, then answer the following questions.

When you run the model, what happens?

Why do the two thermometers reach the same temperature?

Record the results of at least three different setups of initial temperature differences.

Results from Model 1A		
Initial temperature of left object	Initial temperature of right object	Final temperature

In Model 1A, what rule can be used to determine the final temperature of the two objects if the objects are identical?

Why does a warm object feel warm when you touch it?

## 1B: Heat storage depends on specific heat

Substances vary greatly in their ability to store thermal energy. The specific heat is a property of a substance that tells how much the temperature goes up when a given amount of energy is added. A large specific heat means you have to put a lot of energy into it each each degree increase in temperature.

In this model the specific heat  $c_p$  of each object is different, as shown by the labels in the boxes. The temperature difference is fixed. But the specific heats can be adjusted. Open Model 1B and follow the instructions, then answer the following questions.

Predict the final temperature under each circumstance using the equation:

$$(c_p m \Delta T)_{\text{left}} = -(c_p m \Delta T)_{\text{right}}$$

Write your predicted results and the measured results of your three experiments below.

Results from Model 1B				
Left-hand $c_p$	Left-hand initial temperature	Right-hand $c_p$	Right-hand initial temperature	Final temperature
1000	40	2000	10	Predicted: Measured:
				Predicted: Measured:
				Predicted: Measured:

Make a general claim. For two materials with different heat capacities, how will the equilibrium temperature be affected?

## Energy2D

### 1C: Heat storage depends on size

In this model the specific heat of each rectangular object is different, as shown in the label below them. The size of an object is a stand-in for mass in the equation, that is, how much material there is. According to the rule of conservation of energy, the amount of heat flowing in or out from the left rectangle must be equal to the amount of heat flowing out or in from the right rectangle.

$$(c_p A \Delta T)_{\text{left}} = -(c_p A \Delta T)_{\text{right}}$$

where  $A_{\text{left}}$  is the size (area) of the left object and  $A_{\text{right}}$  is the size (area) of the right object

Open Model 1C and follow the instructions, then answer the following questions.

Record the results of your experiments below. Note that these should all be results where the final temperature is close to 25 °C (within 1 °C).

Results from Model 1C			
Left-hand $c_p$	Left-hand area	Right-hand $c_p$	Right-hand area
1000		2000	
1000		500	

Use the following equation to explain your results.

$$(c_p A \Delta T)_{\text{left}} = -(c_p A \Delta T)_{\text{right}}$$

Why does it take longer to heat up a bigger house?

# Power and energy

Here is a quick review of the difference between energy (how much) and power (how fast).

Take an oil-fired boiler as an example. They are rated by their power output (BTU/hr or energy/time), which can also be expressed as gallons per minute of oil used. How fast the oil is used is a power rating. How many gallons of oil you use is an energy rating.

Here's a very common conversion problem. The energy in a gallon of oil is about 120,000 BTU, and a kWh of energy is about 3400 BTU. If oil is \$3.00/gal and electricity is \$0.15/kWh, which form of energy is more expensive? Show your results.

# Energy2D

## 2A: The effect of heating power

---

This model compares the rate of temperature rise due to different power inputs. The heat added is the power multiplied by the time:

$$Q = Pt$$

Open Model 2A and follow the instructions, then answer the following questions.

Record the results of your experiments below. Measure the temperature at approximately the same stop time for each experiment.

Results from Model 2A					
Left-hand power	Right-hand power	Power ratio	Left-hand temperature	Right-hand temperature	Temperature ratio
1000		2000			
1000		500			

Compare the ratio of the change in temperatures to the ratio of the applied power in each case:  $\Delta T_{\text{left}} / \Delta T_{\text{right}}$  vs.  $P_{\text{left}} / P_{\text{right}}$

Why does a more powerful heater warm up a room more quickly?

## 2B: Regulating temperature

---

# Energy2D

This model compares the rate of temperature rise when the heat capacities of the boxes are different but the power inputs are the same. This is an exaggerated version of a masonry house (large heat capacity) compared to a wood-frame house (small heat capacity). Open Model 2B and follow the instructions, then answer the following questions.

Which box heated up more quickly? Why?

After you turn the heater on and off, describe the graphs. Which curve was steadier and which was more variable? What was the range of temperature variation in each?

In equal times, which box gained more heat?

## Connection to buildings

### Explore

How would a building with a high heat capacity (masonry) behave differently from a building with a low heat capacity (wood frame)?

Which building might be more comfortable, masonry or wood frame? Why?

When and where is it useful to store heat? Think about different contexts, such as houses, food, cooking, or water and give at least three examples.

# Heat Transfer

## Conduction

### Introduction

Conduction is the transfer of heat through solid materials. Thermal conductivity is the measure of how fast a material conducts heat. The opposite of conductivity is resistivity, or insulating value. Metals, like aluminum or iron, conduct very well, that is, they are good conductors and poor insulators. Materials with air trapped in them, like wool, bedding, or Styrofoam, conduct very slowly; they are good insulators. Most solid materials, like wood, plastic, or stone, are somewhere in between.

---

How does heat flow through solids?

---

### Factors that affect heat conduction

The rate of heat transfer by conduction depends on the conductivity, the thickness, and the area of the material. It is also directly proportional to the temperature difference across the material. Mathematically, it looks like this:

$$\Delta Q/\Delta t = -kA(\Delta T/L)$$

$(\Delta Q/\Delta t)$  = the rate of heat conduction (kJ/s)

$\Delta T$  = temperature difference across the material

$L$  = thickness of the layer (m)

$A$  = area of the material (m<sup>2</sup>)

$k$  = thermal conductivity of the material per unit thickness (kJ/m/s/°C)

The symbol  $\Delta$  (delta) means “change in.” It could also be written as follows:

$$\Delta Q/\Delta t = (Q_2 - Q_1)/(t_2 - t_1)$$

$$\Delta T = (T_2 - T_1)$$

Note that  $\Delta Q/\Delta t$  is the *rate* of heat flow by conduction, that is, how fast it flows through the material. The *amount* of heat flow is  $\Delta Q$ .

# Conductivity of different materials

## Introduction

Your goal in these experiments is to measure and compare the thermal conductivity of different materials that you might use in the walls of your model house. You can do this by heating one side of a material and measuring the temperature difference between the hot side and the cold side. Your source of heat will be a cup of hot water. The situation is just like measuring the inside and outside temperatures of a house wall on a cold day.

The assumption in this experiment is that the temperature difference will be smaller if the thermal conductivity is greater because more heat passes through the material and raises the temperature of the outside sensor. This is not strictly accurate, but it does provide a way to compare different materials.

Note that since the different materials are different thicknesses, this experiment measures the thermal conductivity of the whole material, rather than its conductivity per unit thickness.

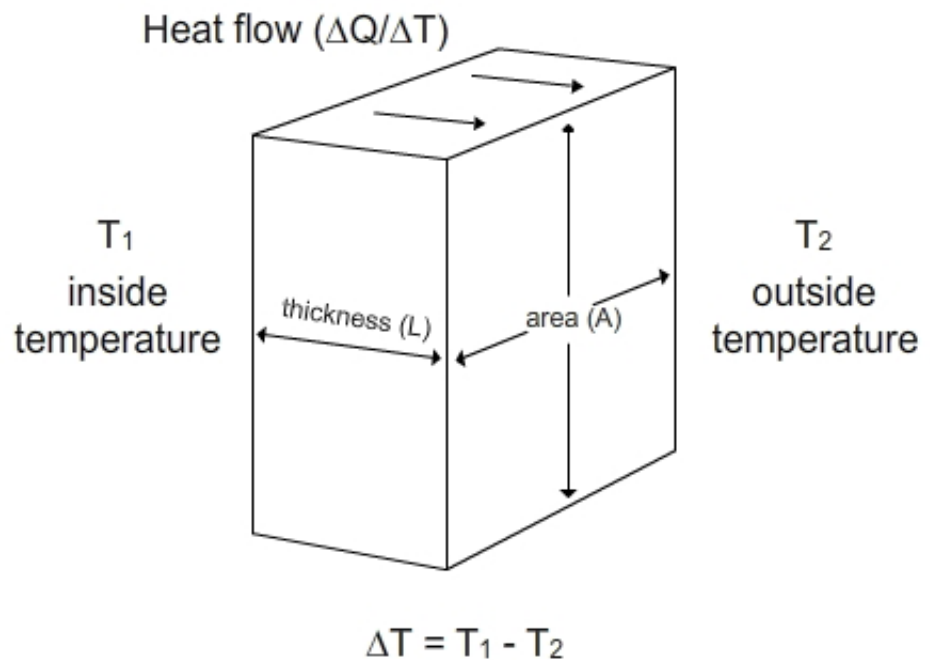

### 3A: Heat conduction through materials

---



Here is a model comparing four common building materials – metal (steel or aluminum), stone (or other masonry, such as concrete or brick), fiberglass, and wood. Open Model 3A and follow the instructions, then answer the following questions.

List the four materials in order of rate of heat transfer.

**3B: The effect of thermal conductivity**

---

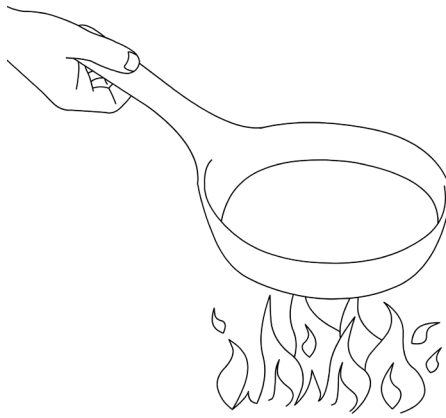

A. metal handle

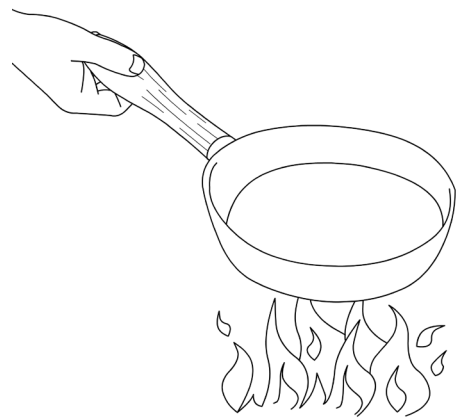

B. rubber handle

When you cook with a frying pan, you may notice that a rubber handle stays cooler than a metal handle.

In this model you will explore the role of thermal conductivity ( $k$ ) on heat flow. Open Model 3B and follow the instructions, then answer the following questions.

Which material has a greater conductivity, the upper or lower material? What is your evidence from the model?

Describe an everyday situation where you have directly experienced the difference in conductivity between two different materials.

### 3C: The effect of wall thickness

---

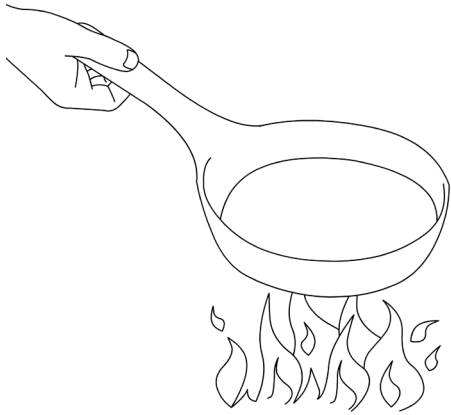

A. hand farther up the handle

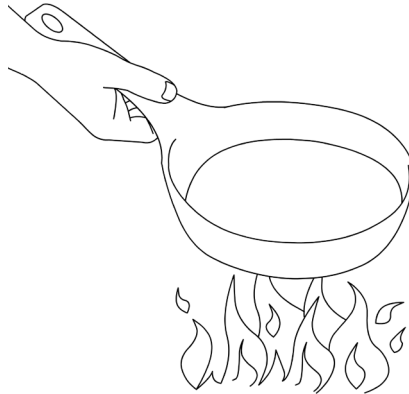

B. hand closer to the pan

You may notice that your hand feels hotter if you hold the handle of a frying pan in the middle as opposed to the end.

In this model you can explore the effect of thickness  $L$  on heat flow. This is a two-dimensional model, so the thickness is represented by the distance between the heat sources – a left-to-right measurement. Open Model 3C and follow the instructions, then answer the following question.

Compare the two cases. How does wall thickness affect heat flow?

### 3D: The effect of contact area

---

In this model you can explore the effect of area  $A$  on heat flow. This is a two-dimensional model, so the area is represented by the vertical length of the test pieces. A wider test piece is like having more contact area. Open Model 3D and follow the instructions, then answer the following questions.

Results from Model 3D	
Contact area	Energy at half hour

How does contact area affect heat flow? Use evidence from your table.

Picture two houses with the same floor area and the same wall insulation values. One is almost square, with two stories. The other is one story and L-shaped. Which one is likely to have greater total heat loss through the walls? Why?

### 3E: The effect of temperature difference

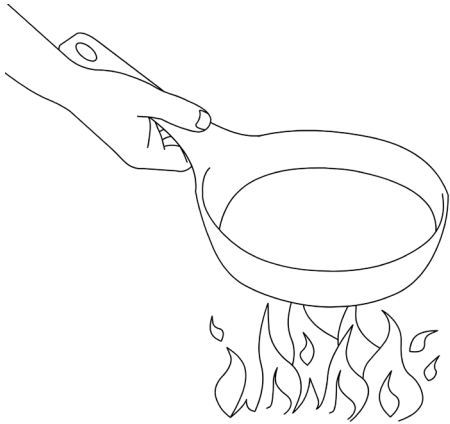

A. more intense heat source

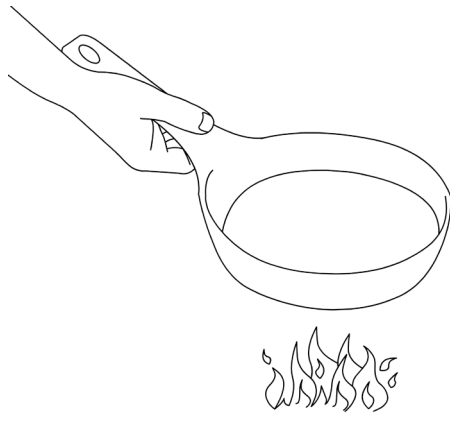

B. less intense heat source

If the fire below a frying pan is more intense, your hand will feel hotter.

In this model you can explore how the amount of heat conducted through an object depends on the temperature of the heater. Open Model 3E and follow the instructions, then answer the following questions.

Results from Model 3E	
Temperature of heater	Temperature of thermometer at half hour
50	

Does a hotter object lose heat more quickly than a colder object?

### Instructions

1. Make a claim. Answer the first question with one or two sentences only.
2. For the second question, use evidence, data, examples, results, or descriptions from your experiment(s) and/or model-based activity.
3. For the third question, apply what you learned from your experiment and model-based activities to support the claim you made.

**Claim:** What part(s) of a house lose(s) the most heat by conduction?

**Evidence:** What did your experiments show you about how different materials conduct heat?

**Reasoning:** How do the results of your experiments explain your claim above?

## Temperatures inside walls (optional)

Most house walls consist of several layers. The total R-value is the sum of all of them. In addition, there is some insulating value of the still air right next to the surface, both on the inside and the outside of the wall. Note: only air that is not moving provides some insulating value. If the wind is blowing, the insulating layer of air is stripped away.

Here is a diagram of a typical wall and the temperature change across the materials. The temperature drop is directly proportional to the insulating value of each portion of the wall. That is, the largest difference in temperature will be across the most insulating part of the wall.

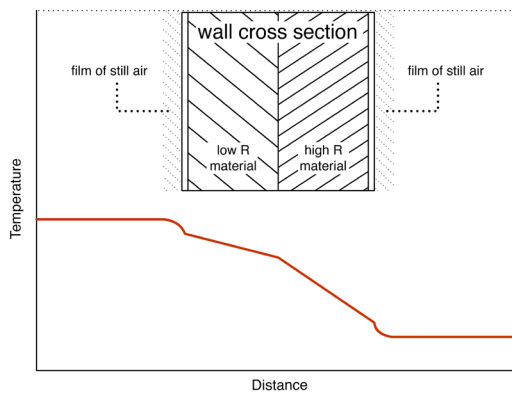

### 3F: Temperatures inside walls (optional)

**Energy2D**

Here is a model of a wall with several layers. Open Model 3F and follow the instructions, then answer the following questions.

Rate the materials (A, B, C) from greatest to least temperature drop. This may take some experimenting on your part – changing the order, turning on the graphs and waiting until the temperature is steady.

Rate the materials (A, B, C) from greatest to least conductivity.

Explain what you did to figure this out.

## Conductivity and heat capacity combined

It's easy to confuse heat capacity (thermal mass) with insulating value. Heat capacity is the ability to *store* heat. An object with more heat capacity takes longer to heat up or cool down because more heat is required to change its temperature.

Conductivity is how easily heat will *flow* from one place to another. A more insulated object takes longer to heat up or cool down because the heat flows more slowly into it or out of it.

Insulating materials generally have low heat capacity (because they are mostly air) and low conductivity. It takes very little heat to warm them up, but getting the heat into and out of them is slow. So the heat flow looks like this:

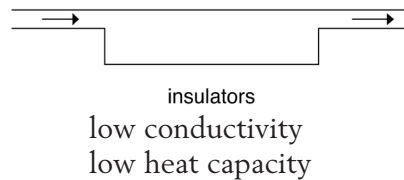

Masonry materials generally have high heat capacity and fairly high conductivity. It may take a lot of heat to warm them up, but once they are "full", the heat will flow through them quickly. The heat flow looks like this:

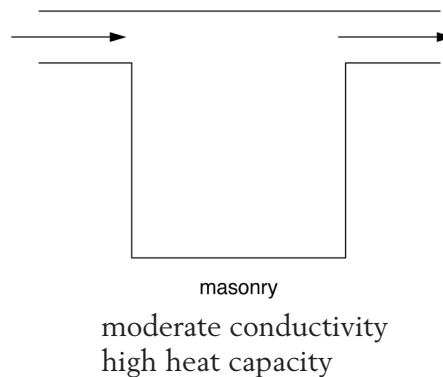

Metals have a low heat capacity and very high conductivity. They are easy to heat up, and heat flows through them easily. The heat flow looks like this:

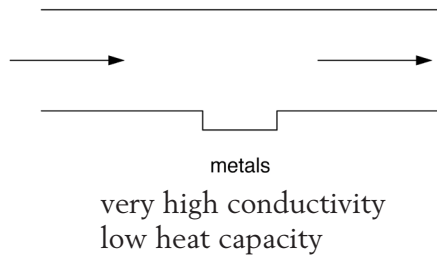

## Energy2D

### 3G: Combine thermal conductivity and heat capacity

---

This model shows the combined effects of heat capacity and conductivity. Open Model 3G and follow the instructions, then answer the following questions.

Describe what happens in the three cases. Refer to both the "thermal energy" view and the "temperature" view. What role does heat capacity play in the process of heat transfer?

Which material is the best insulator?

# Connection to buildings

---

Homework

(pages 53-55)

---

## Background

In the building trades, the rate of heat loss is called conductivity (U), which is the same as k, seen on page 31. The most common measure of conductivity is its inverse: resistance to heat flow, called R or R-value.

**R (thermal resistivity) = 1 / U (thermal conductivity)**

The greater the value of R, the more slowly heat is lost. Doubling R-value means the rate of heat loss is cut in half.

The American building trades don't use metric units. For instance, heat flow is measured in British Thermal Units (BTU) per hour, instead of kilojoules per second. Temperatures are in Fahrenheit rather than Celsius. Thickness is in inches, and area is in feet instead of meters.

To do real calculations on a building, you must get used to doing lots of conversions of units! This project will focus on the relative behavior of different materials, rather than exact calculations.

R can be given per inch of material or for the whole assembly. For example, many common insulating materials have an R-value of 3 to 5 per inch, in standard American units. Fiberglass in a 5 1/2" wood frame wall adds up to about R-20. Insulation in ceilings and roofs, where there's more room for insulation, is commonly R-30 to R-40.

Windows typically have the lowest R-value in the building envelope: R-1 for single glazed, R-2 for double glazed, and R-3 or 4 for triple or specially treated glazing. So the typical wall is five to ten times as insulating as the typical window. But there is five to ten times as much wall area as window area, so the two elements contribute equally to the total heat loss, roughly speaking.

Note that the true insulating value of a wall or ceiling depends very much on the quality of workmanship. Gaps and voids can radically reduce the nominal R-value.

Material	Approximate R-value in US units
2x4 wall with insulation	12
2x6 wall with insulation	20
12" of attic insulation	45
12" masonry or concrete foundation wall	2
Single sheet of glass	1
Insulated glass	2
High-performance insulated glass	3
Insulated door	5

Masonry is surprising. It has a high thermal heat capacity, but its R-value is low. That is, it stores a lot of heat, but it also conducts heat well. An 8" masonry or concrete wall has only as much R-value as a double-glazed window (about  $R = 2$ )!

## Connection to buildings

### Explore

Describe the advantages of a well-insulated house.

Recall that heat loss is proportional both the conductivity and the area of a surface such as a wall. If a house had ten times as much wall area as it had window area, and the wall was ten times as insulating, what would be the relative heat loss from wall and window?



# Heat Transfer

## Convection

### *Introduction*

Convection is defined as the circulation of fluids (liquids or gases), either natural or forced. Hot or cold fluids can bring or remove heat. Natural convection is caused by density differences. Hot air rises because it is less dense than cold air, so air will rise above a heater and sink near a cold window. Forced convection refers to fluids being pushed around by outside forces. A fan or a pump are forms of forced convection, which is very useful for moving heat from one place to another.

In this section you will investigate the effects of convection in a house.

### *Natural convection*

Hot air rises, because it's less dense than cold air. Warm air in a room quickly rises upward, and cold air sinks downward, even if the temperature differences are quite small.

---

How do fluids carry heat from one place to another?

---

Can air carry heat into and out of a house?

---

# Energy2D

## 4A: Natural convection

What would it be like if there were no natural convection, that is, if air didn't move around when heated or cooled? This model compares the two situations: convection by air that is free to move and conduction through a solid with the same conductivity as air. Each is placed above a hot plate. Open Model 4A and follow the instructions, then answer the following questions.

Measure top temperatures at half an hour for different bottom temperatures. Record the results of your experiments below.

Results from Model 4A		
Bottom temperature	Top temperature above air	Top temperature above solid

Based on the model, explain the difference between convection and conduction. Which is faster?

## 4B: Slow down convection

---



Suppose you could interrupt convection flow with one or more barriers. This is essentially what insulation does. Most insulation consists of tiny pockets of air separated by thin walls or fibers that stop large-scale convection. Open Model 4B and follow the instructions, then answer the following questions.

How can convection in air be reduced?

### Instructions

1. Make a claim. Answer the first question with one or two sentences only.
2. For the second question, use evidence, data, examples, results, or descriptions from your experiment(s) and/or model-based activity.
3. For the third question, apply what you learned from your experiment and model-based activities to support the claim you made.

**Claim:** Give an example where heat is transferred by convection in a house.

**Evidence:** What did your experiments show you about natural convection?

**Reasoning:** How do the results of your experiments explain your claim above?

## Forced convection

Forced convection refers to motion of a fluid that is not caused by differences in density between warm and cold (“hot air rises”). A fan (air) or a pump (water) is an example of forced convection. It is a very useful way to move heat around. For example, hot-air heating and air conditioning systems use large ducts to transport warm or cold air around a building.

Water can also carry heat from one place to another by being pumped through pipes, that is, by forced convection. The great advantage of water is its enormous specific heat. Large amounts of heat can be transported from the boiler to all corners of the building. It is then transferred to the air in various ways.

Wind chill describes the cooling effect of moving air across a warm surface, such as our skin. The cause of wind chill is simple, and it depends on the difference between conduction and convection. Air is a very good insulator, if it doesn’t move. Most good insulators – wool, foam, fiberglass – trap air in tiny pockets so that it can’t circulate. Heat conducts very slowly across each little air pocket.

On the other hand, air moves very easily in larger spaces, driven by even the slightest temperature differences. When it moves, warm air carries heat from one place to another. Large air spaces in walls are not good insulation because the air moves freely and carries heat from one side to the other.

Picture a hot surface (such as your skin) with cold air above it. Right next to the surface is a thin layer of still air that provides some insulating value because it is not moving. Imagine what happens when you turn on a fan. Your skin cools off because the still air layer is stripped away, and the skin surface is directly exposed to the cold air.

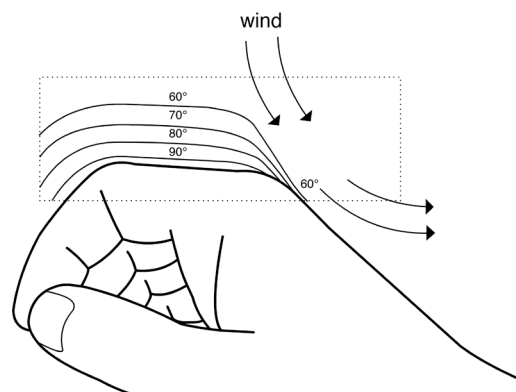

# Energy2D

## 4C: Forced convection

---

Here's a model that explores forced convection, the effect of wind blowing across a hot surface. Open Model 4C and follow the instructions, then answer the following questions.

Record the temperatures of the upper and lower sensors after running the model for 0.4 model hours as shown on the graph (not real time) under three wind conditions.

Results from Model 4C		
Wind speed	Temperature at upper sensor	Temperature at lower sensor
Low		
Medium		
High		

Explain why a temperature difference develops between the circles.

Think of other examples of the wind chill effect and how it is minimized.

# Infiltration

## Introduction

Infiltration refers to outside air leaking into a house. This implies that inside air is also leaking out (exfiltration), so infiltration is loosely used to describe the exchange of air between inside and outside. If the inside air is warm and the outside air is cold, lots of heat can be lost, and the house will be drafty and uncomfortable.

Infiltration can be driven by two forces: a) the “stack effect” or the “chimney effect,” where rising hot air pushes outward at the top of a building and cold air is drawn inward at the bottom; b) wind, which creates greater pressure on one side of a building than the other.

You will explore infiltration further when you test your own model house in Chapter 4.

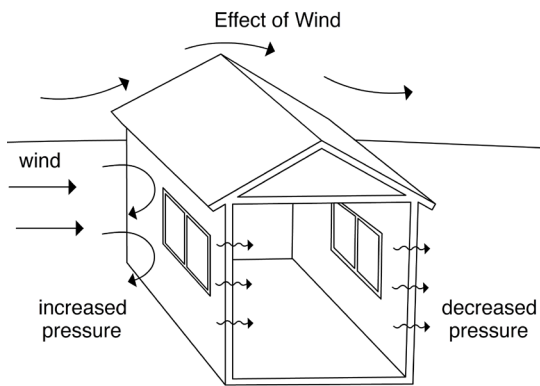
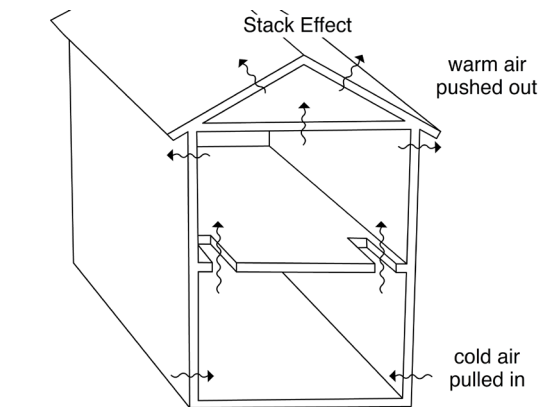

## Energy2D

### 4D: Stack effect

---

Here is a model that demonstrates the stack effect. Open Model 4D and follow the instructions, then answer the following questions.

Draw the convection pattern as shown in your model after you changed the size and location of leaks in each room. Describe or use arrows to show the motion of the air.

What causes more loss of energy, a leak near the ceiling, or a leak near the floor? Why?

## 4E: Blowing wind (optional)

This model shows a wind blowing across a building. Open Model 4E and follow the instructions, then answer the following questions.

Draw the motion of the air outside the building before you open the windows. What do you notice about air motion right next to the building?

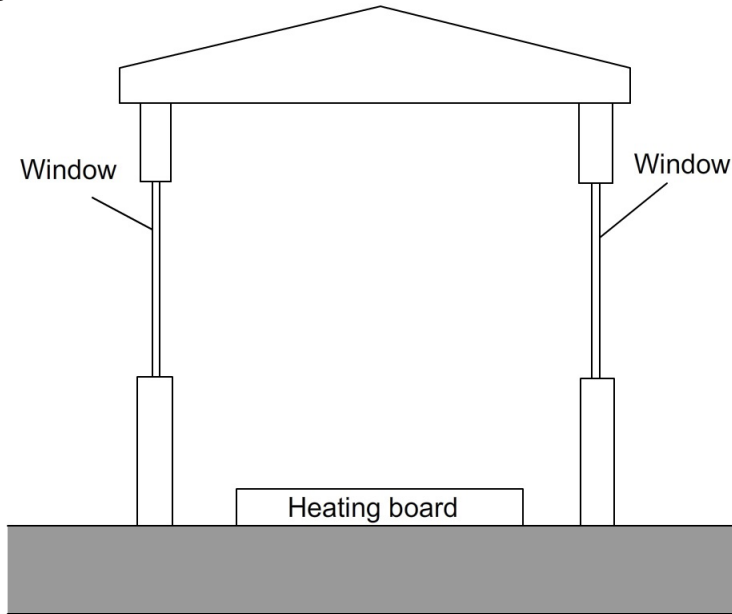

In the same picture above, draw the motion of the air inside the building before you open the windows.

Describe how the motion of the air changes inside the building:

a. when there is a wind and the windows are open

b. when there is **no wind** and the windows are open

## Connection to buildings

### Explore

There are two ways convection might cause a building to lose heat:

1. Hot air leaks out through holes in the building (infiltration driven by the stack effect).
2. Moving air lowers the surface temperature of the building (wind chill effect) and increases the heat loss from the walls and windows. It also enters the building through cracks and holes (infiltration).

Suggest how you might cut down on these forms of heat loss in a real house.

Have you noticed differences in temperature between different rooms or levels in your house, or between the ceiling and the floor? Explain why in terms of conduction and convection. Why?

## Summary

Here is a cross-section of your standard house. There is a leaky joint near the ceiling and another one near the floor. Suppose the average temperature is  $40\text{ }^{\circ}\text{C}$  inside and  $20\text{ }^{\circ}\text{C}$  outside.

- Draw what you think the heat distribution might be in the house by writing temperature values in five different locations.
- Draw arrows to show what you think the motion of the air might be due to convection.

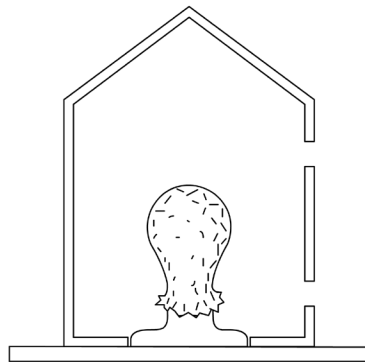

Now suppose the leaks were sealed up. How would it be different?

- Draw what you think the distribution might be in the house by writing temperature values in five locations.
- Draw arrows to show what you think the motion of the air might be due to convection.

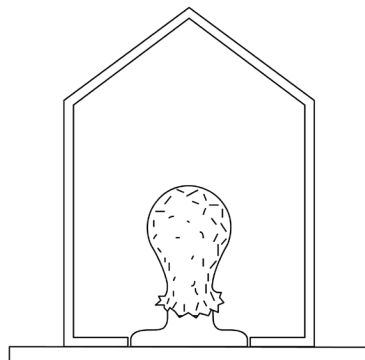



# Heat Transfer

## Radiation

### Introduction

In this activity you will explore infrared radiation, which you can't see but can feel as heat.

Radiation is the common name for electromagnetic energy traveling through space. It goes very fast (ten times around the earth in one second) and can pass through a vacuum. It doesn't need material to travel in. It has many forms, including visible light, infrared (IR), ultraviolet (UV), X-rays, microwaves, and radio waves. These are all the same form of energy, just with different frequencies and amounts of energy. Different frequencies of radiation interact with matter differently, which makes them seem more different to us than they really are.

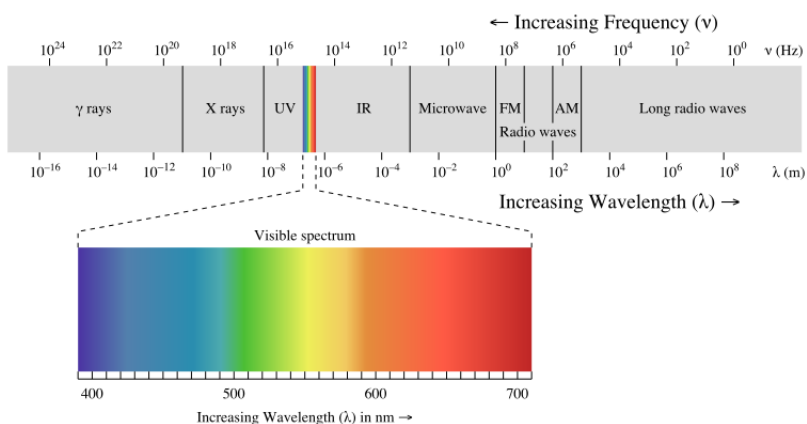

*Wikimedia Commons, EM spectrum.svg, Creative Commons Attribution ShareAlike 3.0*

Radiation is not heat. Radiation and heat are two different forms of energy. But one is often transformed into the other in everyday situations. Thermal energy is often transferred by radiation, mostly in the infrared (IR) and visible range. All materials that are warmer than absolute zero ( $-273\text{ }^\circ\text{C}$ ) give off radiation due to the fact that their atoms are vibrating. The amount of radiation is proportional to the fourth power of the temperature ( $T^4$ ), measured from absolute zero. So, the hotter an object, the more radiation it emits.

---

Do objects at room temperature give off radiation?

---

Also most surfaces absorb radiation and transform it into heat. White surfaces reflect visible light, but absorb infrared. Black surfaces absorb both visible light and infrared. Shiny surfaces reflect both of them.

The fact that all objects give off radiation energy is a little surprising. We usually imagine that only “red hot” materials radiate, because we can’t see other wavelengths that aren’t visible light. This experiment will explore radiation from objects at ordinary temperatures. This radiation is mostly in the infrared range, which is right next to visible light but with longer wavelengths. Note the infrared range on the chart above.

## 5A: Radiation energy depends on temperature

---

# Energy2D

This model shows two objects at different temperatures that are giving off electromagnetic radiation. Open Model 5A and follow the instructions, then answer the following questions.

Describe the effect of temperature on the intensity of radiation, and hence its heating effect on objects that absorb it.

Think of a real-world situation where you have felt radiation from something hot and something cold even though they were not visibly hot or cold.

### Instructions

1. Make a claim. Answer the first question with one or two sentences only.
2. For the second question, use evidence, data, examples, results, or descriptions from your experiment(s) and/or model-based activity.
3. For the third question, apply what you learned from your experiment and model-based activities to support the claim you made.

Claim: Explain why it is uncomfortable to sit near windows on a cold night even if they are tightly sealed and don't let cold air in.

Evidence: What did your experiments show you about radiation energy?

Reasoning: How do the results of your experiments explain your claim above?

# Connection to buildings

## Background

---

## Homework

---

Passive solar heating consists of letting in sunlight energy (mostly visible light) and stopping heat loss, some of which is IR radiation outward from the warm building. There's a trade-off between the two processes. Larger windows gain more sunlight, but they also lose much more heat than walls. There have been considerable technical advances over the years to make windows that are transparent (let light in), but also have a high insulating value (keep heat in).

For example:

- two layers of glass (three layers in northern climates), with an air space between
- argon gas in the air space, which is less conducting than regular air
- “low-emissivity” coatings on the glass surfaces, which reduces the emission of radiation from the glass itself. If you coated the jar of hot water in this way, the radiation meter would not show a temperature rise when it faced the jar.

Picture a room with large windows on one wall and a steam radiator on the opposite wall. Steam radiators are large cast-iron objects that get very hot — almost too hot to touch. At night, or when the sun is not shining, show all of the ways that the heat from the steam radiator becomes distributed throughout the room.



# Heat Transfer

## Energy from the Sun

### Introduction

The sun rises in the east and sets in the west, but its exact path changes over the course of the year, which causes the seasons. In order to use the sun's energy in a building, we need to know where it is in the sky at different times of the year.

There are two ways to think about the sun's path in the sky. One way is to study the tilted Earth traveling around the sun viewed from outer space and figure out where the sun would appear in the sky at your latitude at different times of the day and year. If you have time, give this a try with your class.

Walk around a light source, real or imagined, with a globe that's tilted at the right angle. Turn the globe at different positions (times of the year). Try to picture the length of the day and the angle of the sun.

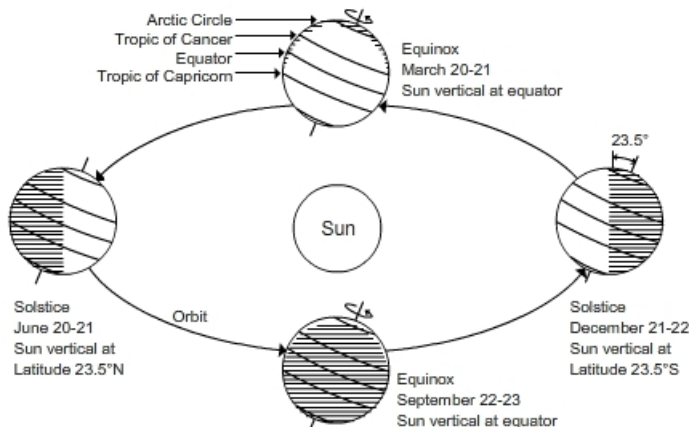

The other way is to stand on the Earth and plot the path of the sun from your point of view on the ground. This is easier to apply to a building, although, of course, the two ways give the same results.

We will use the earth-centered approach in this workbook.

Here is a diagram of the sun's path in the sky at different times of the year. It is roughly correct for a northern latitude of  $40^\circ$ . Note the three lines showing the sun's path. One is the summer solstice, one is the spring and fall equinoxes, and one is the winter solstice.

One is the summer solstice (June 21), one is the spring and fall equinoxes (March 20 and September 23), and one is the winter solstice (December 21). The exact dates change a little bit from year to year.

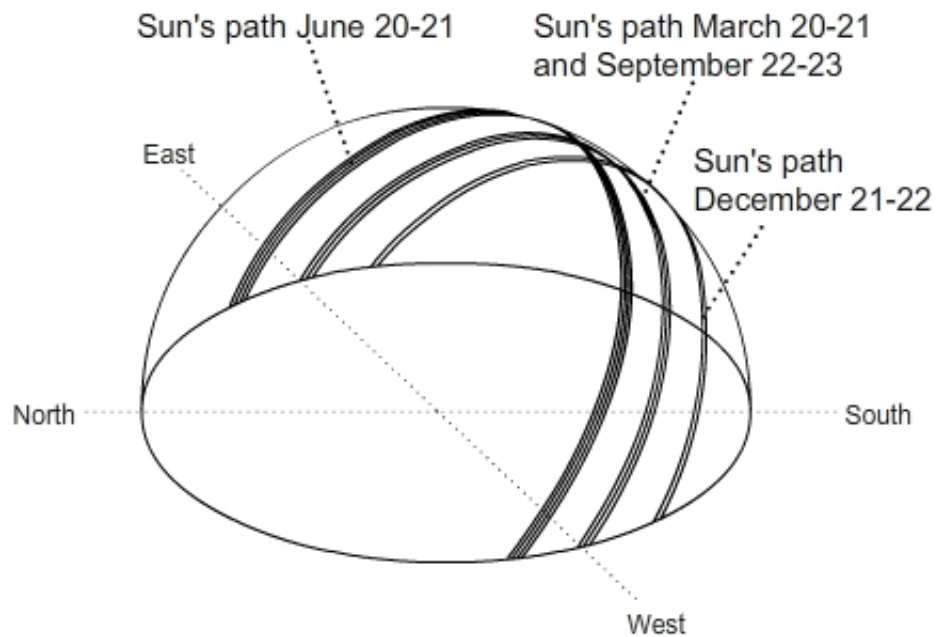

Learn the basic facts about the sun's path at your latitude. Use the above diagram, your background knowledge, and class discussion to fill out the following table. Here are some hints.

---

## Homework

---

- a) At the equinox at noon, the angle of the sun above the horizon is ( $90^\circ$  latitude). For example, at the equator this is  $90^\circ$ ; at the pole this is  $0^\circ$ .
- b) At the two solstices, the angular height of the sun at noon either increases or decreases by  $23.5^\circ$  – the tilt of the earth's axis – compared to the equinox.
- c) For the length of the day, do some Internet research. Many sites give the times of sunrise and sunset.

Sun's path throughout the year					
Your latitude:					
Event	Date	Length of day	Height of sun at noon	Sun rises in what direction?	Sun sets in what direction?
Winter solstice					
Spring equinox					
Summer solstice					
Fall equinox					

Before you continue, the teacher will lead a discussion on the Sun's Path Calisthenics so that this diagram makes more sense.

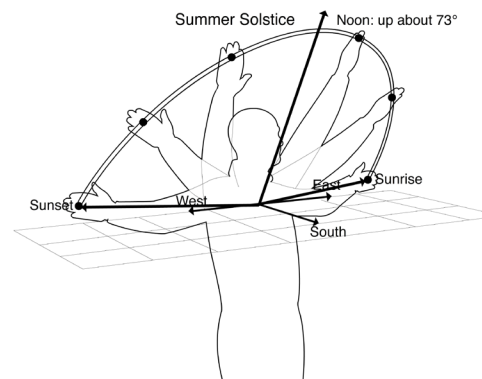
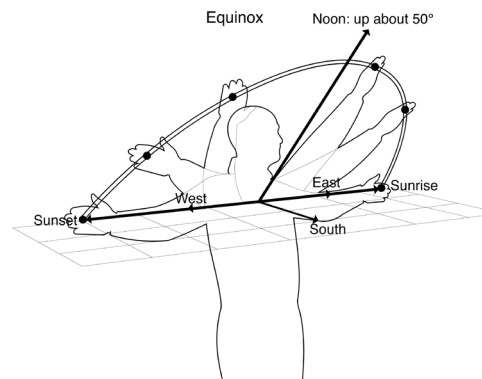
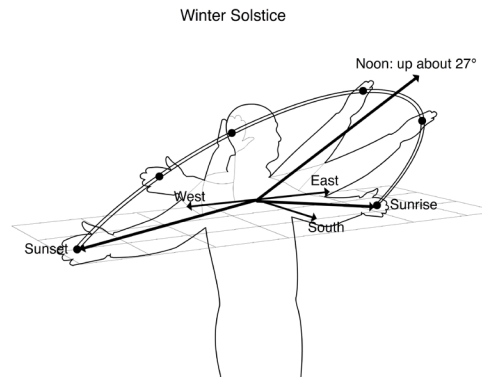

## 6A: The sun's path at your latitude

---



This model shows a house in a field with the sun moving overhead. When the model is run (the green arrow), the sun moves around the earth and appears as it would from the house. Click on the pole with the shadow (upper left) to display the shadow of the house.

The yellow grid shows the possible range of the sun's position over the year for that latitude on the earth. You can change time of day, time of year, and latitude so that you can find the sun's path in the sky anywhere on earth.

Open Model 6A and follow the instructions. Set the latitude to your latitude. Use the "Date," "Time," and "Latitude" buttons on the tool bar to change time of day, time of year, and latitude. Examine, qualitatively, each of the facts that you wrote in your previous table. Then answer the following questions.

Why does the length of the day change from summer to winter?

Is the length of daylight exactly 12 hours for every latitude at the equinox?

At what times of year and times of day is there sunlight on the north face of the house?

## 6B: The sun's path at different latitudes

---

Use the model to explore the sun's path at other latitudes. Open Model 6B and follow the instructions, then answer the following questions.

Describe what is special about the sun's path and the length of day at the equator.

Describe what is special about the sun's path and the length of day near the North or South Pole.

The sun always travels at the same speed across the sky ( $15^\circ$  per hour). If that's true, why does the length of the day change from summer to winter?

Based on your sun's path diagram, explain why it's warmer in summer than in winter when you are not near the equator.

## 6C: Sunlight on a building (optional)

---



Use the model to explore when sunlight falls on different sides of a building. Also note whether the sunlight is perpendicular to the surface (most heating) or at an angle (less heating).

Open Model 6C and follow the instructions, then answer the following questions.

Note the times of day and the times of year that there is direct sunlight on the different surfaces of the building. Use the entries 4, 3, 2, 1, and 0, with 4 being the most direct and 0 being no direct sunlight.

Results from Model 6C		
Wall orientation	Times of day	Times of year
North side:		
East side:		
South side:		
West side:		
Top:		

What orientations should be avoided in the summer?

What orientations are good for winter solar heat gain?



# Heat Transfer

## Energy Detective (optional)

### *Introduction*

As a wrap-up, use the model to explore heat flow in a whole house model. You can move temperature sensors around, just as you would with real temperature sensors in the standard house model. The advantage of a computer model is that you can change features and make measurements very quickly. And you can also add as many sensors as you want. On the other hand, a model is never just like the real world.

### 7A: A well-insulated house vs. a poorly-insulated house

---

**Energy2D**

Use the model to investigate the quality of construction of the two houses. Open Model 7A and follow the instructions. Then answer the following questions.

Which house required more power to keep warm, A or B? Explain how you figured this out.

Go back to the model and do more tests to answer these two questions. Recall that the rate of heat loss is proportional to the difference between inside and outside temperatures.

1. How much more power, roughly, does the less energy-efficient house require (for example, 1 ½ times, 2 times, 3 times, 4 times as much power)? Note: remember you calculated power requirement for your standard house. See page 16.

2. What is the ratio of high heater power to low heater power?

**7B: Where does this house lose heat the most?**

---

Use the model to investigate the quality of construction of different parts of the model house. Open Model 7B and follow the instructions. Then answer the following questions.

Describe the method and measurements you used to find the poorly insulated places.

Fill out the following table with results from Model 7B.

Results from Model 7B		
Building section	Insulating quality (great, good, fair, poor)	Evidence (measurements)
A		
B		
C		
D		
W		
R		
G		

## 7C: Discover a vertical temperature gradient

---

You have probably noticed that houses are often warmer near the ceiling than near the floor, and warmer upstairs than downstairs. This model shows the effect of natural convection in a house. Open Model 7C and follow the instructions. Then answer the following questions.

Results from Model 7C		
Thermometer	Temperature with ceiling	Temperature without ceiling
T1		
T2		
T3		

Describe the effect of removing the ceiling.

Many modern houses have living rooms in two-story spaces, so that the ceiling is 12 or more feet high. Explain why this kind of space is difficult to heat, and what you could do about it.

## Summary

Think about a house you'd like to design. What directions and slopes (vertical, sloped, horizontal) would you choose for large windows? What directions and slopes would you choose for smaller windows? Why?

## Chapter Summary

Explain the difference between conduction, convection, and radiation. Give an example of each process.

# Chapter 3: Design and Build Your Own House

## Introduction

Now that you have some background about heat transfer and some experience with taking measurements, it's time to design and build your own energy-efficient house.

Your success will be measured using the same tests that you did with your standard house:

- keeping the house warm with a heater light bulb (the “no sunshine” condition)
- reducing the heating requirement using sunshine from a low angle (the “winter sunshine” condition)

The setting is the temperate climate of the northern United States: hot summers and cold winters, with moderate spring and fall seasons. There is a fair amount of sunshine all year, but of course the angle of the sun and the length of the day change significantly from season to season.

As you have seen with your standard house experiments, the two basic strategies are to cut down on heat loss and to gain some heating from the sun during cold months. You are limited to *passive* solar strategies. Designs that depend on collectors, pumps, and fans are called *active* solar collectors and they are not available in this project.

The initial materials will be the same as for the standard house: cardstock, clear acetate, and tape. You must write down a design rationale before you start building and testing. After you test it, you can start trying other materials and modifications to make it perform better. (See Chapter 4).

You will be using a computer program, Energy3D, to design and build your house. The process has three steps:

1. Design the house on the computer, using Energy3D. Make three different designs.
2. Review the three designs and choose the best one for building and testing.
3. Print the chosen design, scale up each piece on cardstock, and assemble the house.

---

Design a model house that uses as little energy as possible to keep it warm.

---

## Design goals

The design of the house is up to you, but there are specific goals that you should address:

- The house has features that you think will make it energy efficient.
- The interior would be comfortable to be in on a sunny day or a cold night.
- The house should be attractive and have “curb appeal.”

In addition there are geometric limitations:

- The house should not be larger than the 28 x 36 cm platform provided in the software.
- To make room for the heater light bulb, the walls must be at least 20 cm high and you can cut a 12 cm diameter hole in the center of the floor.
- The house must be buildable – that is, not too complex and not too many pieces.
- The minimum window area is 50 cm<sup>2</sup>.

Note: In your initial design, you are limited to cardstock and clear acetate as basic building materials.

# Design rationale

Before you begin designing your house on the computer, brainstorm with your team about the goals and how you will address each one. Then answer the following questions.

What shape of the building will contribute to the house's energy efficiency?

What roof shape will contribute to the house's energy efficiency?

How will you orient the building to take advantage of sunlight? What window sizes and placement will be good for solar gain?

Describe the other features that you would like your house to have in order to meet the design goals.

What evidence from your experiments in Chapter 2 are you using to determine these features?

# Building instructions

## Design procedure

1. Watch the Energy3D movie (Getting Started with Energy3D) that is on your USB stick.
2. Open Energy3D and construct your house on the computer. Pay attention to the directions, especially which way is south. This should affect many of your decisions.
3. Your house may not look like the example, but it shows a procedure you can follow. It's OK to experiment with different shapes and start over several times if you want to. Keep the house relatively simple. Remember, what you design you must build out of paper!
4. The program will open with a 28 x 36 cm platform. You house must fit within this.

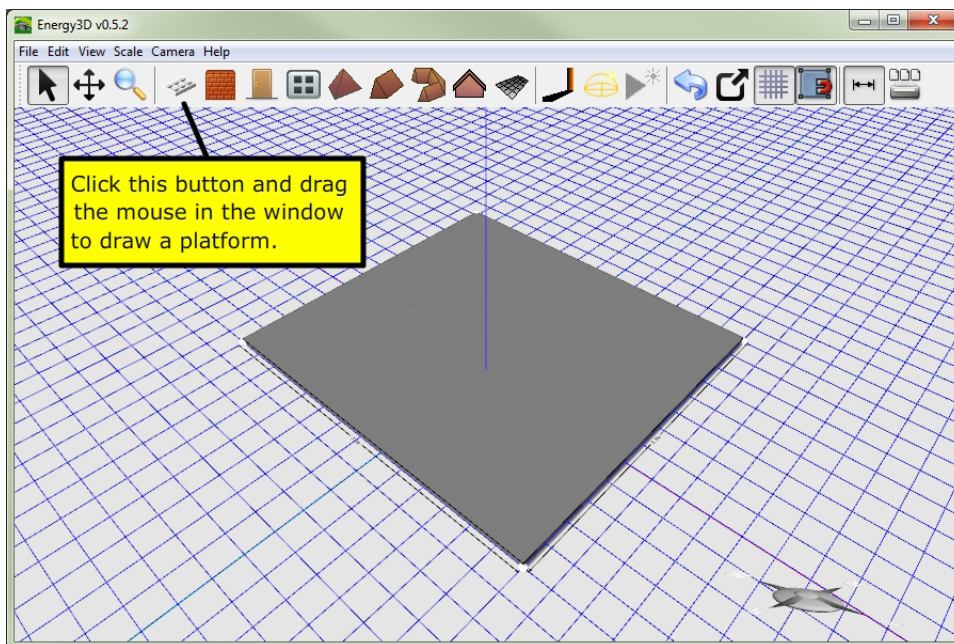

## Tools & materials

- Scissors
- Pencils
- Metal ruler (cm)
- Protractor
- Safety utility cutter
- Cardstock (one 20x30 in sheet)
- Acetate sheets for windows
- Masking tape and/or clear tape
- Temperature sensor
- Computer
- One 40 W heater light bulb in a socket, covered with foil
- One sun light bulb in a gooseneck desk lamp
- Pre-cut 28 x 36 cm platform

5. Build all of the walls first, one at a time. They should be at least 20 cm high to make room for the heater light bulb.

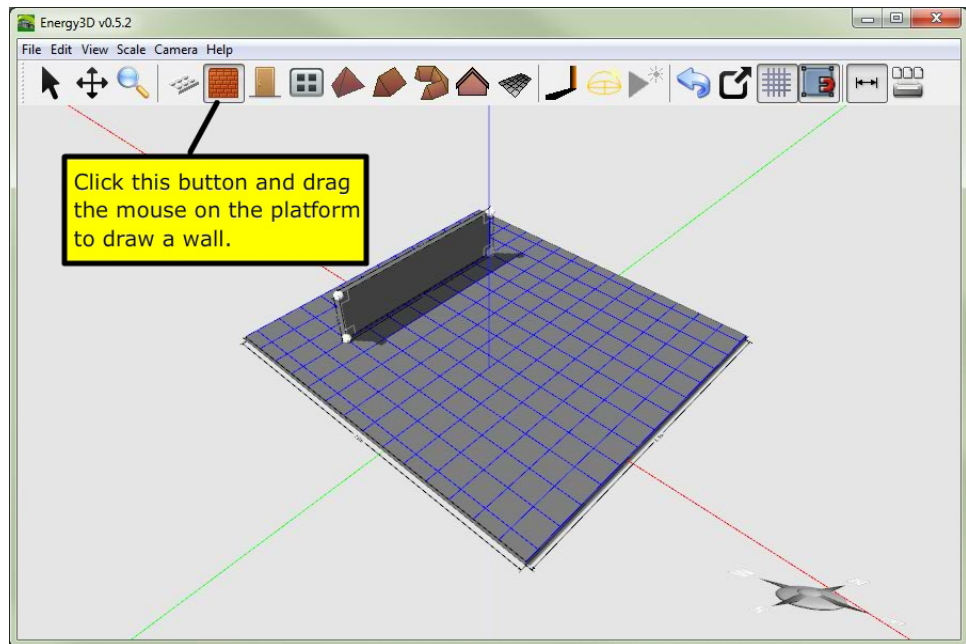

6. Lock the ends of the walls together and make a complete enclosure.

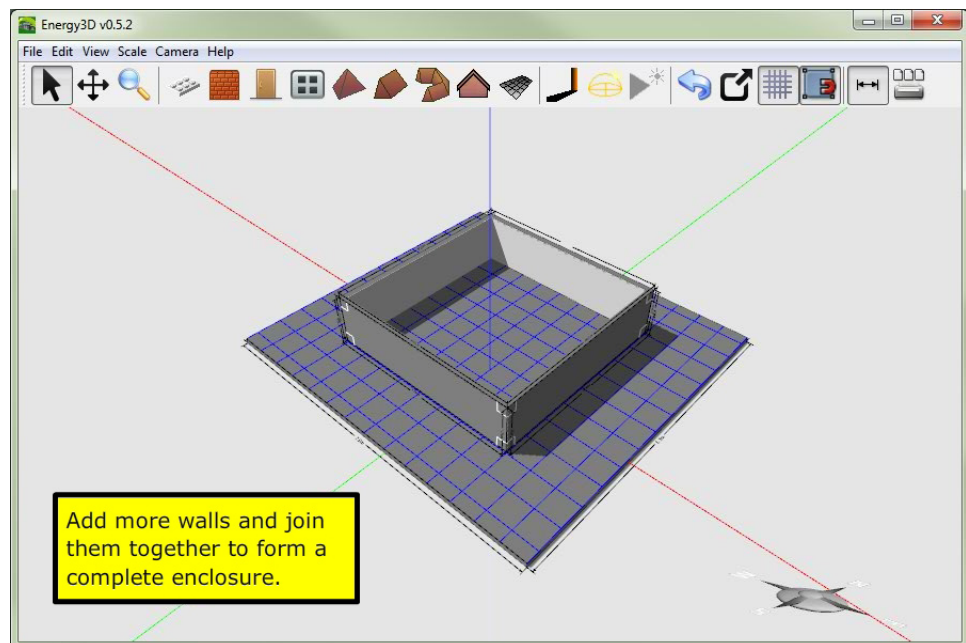

7. Create a floor inside the house. This will help you assemble it.

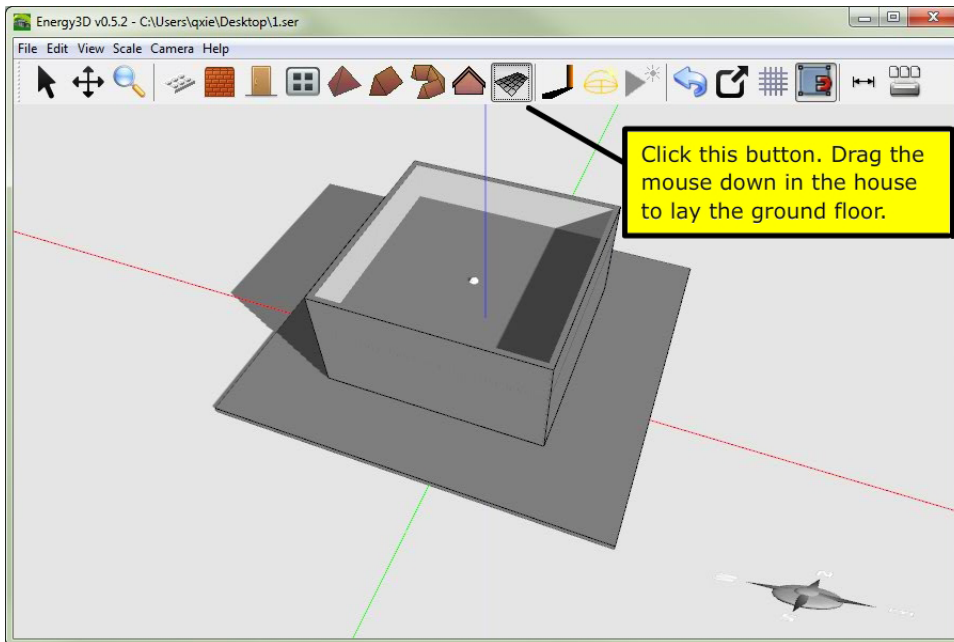

8. Add the roof last, after you have made the basic shape and size of the house.

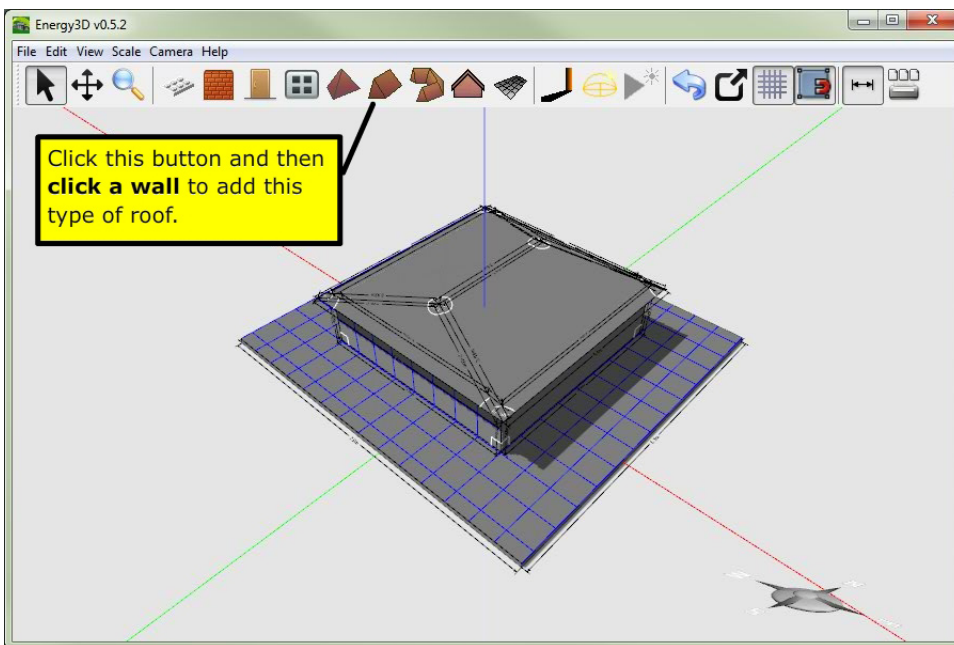

9. After the roof is added, you can change it from a hip roof (above) to a gable roof (below) if you wish.

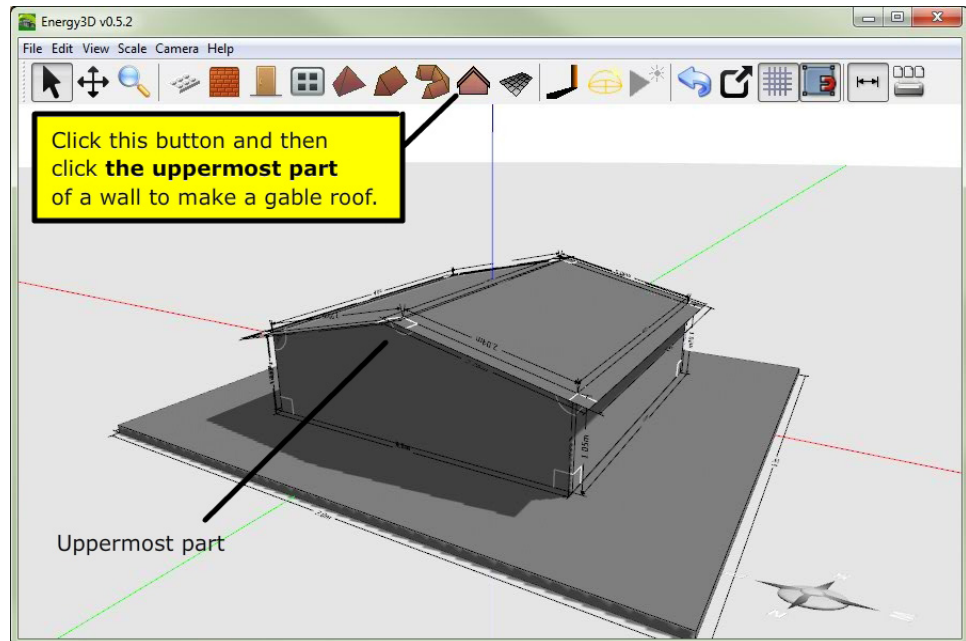

10. The walls must be at least 20 cm high. You can resize them all at once. You can also resize the house in other directions if you need to.

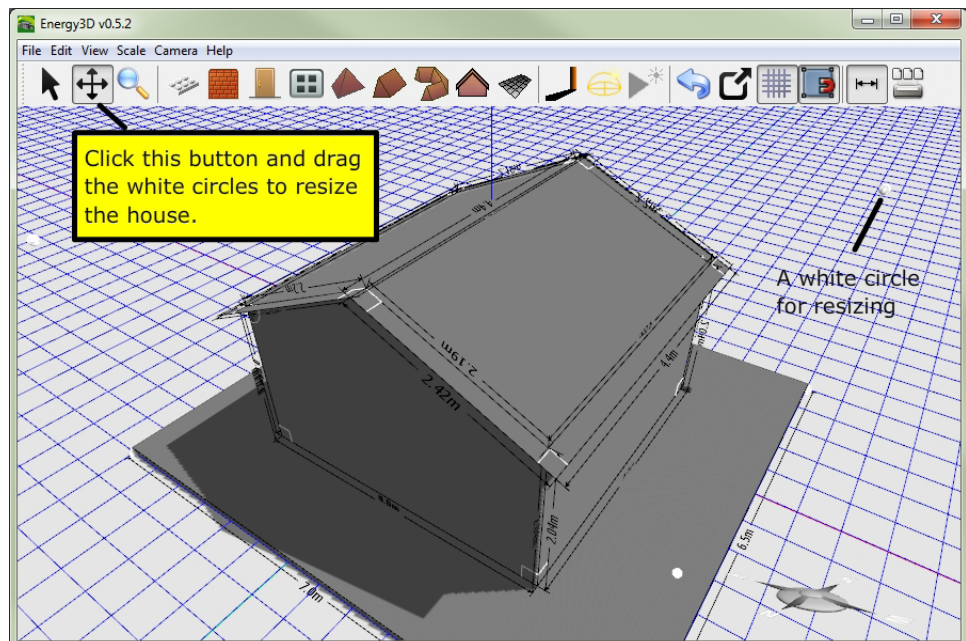

11. Add windows. Pay attention to which direction they face. Don't use too many. They are time consuming to scale up.

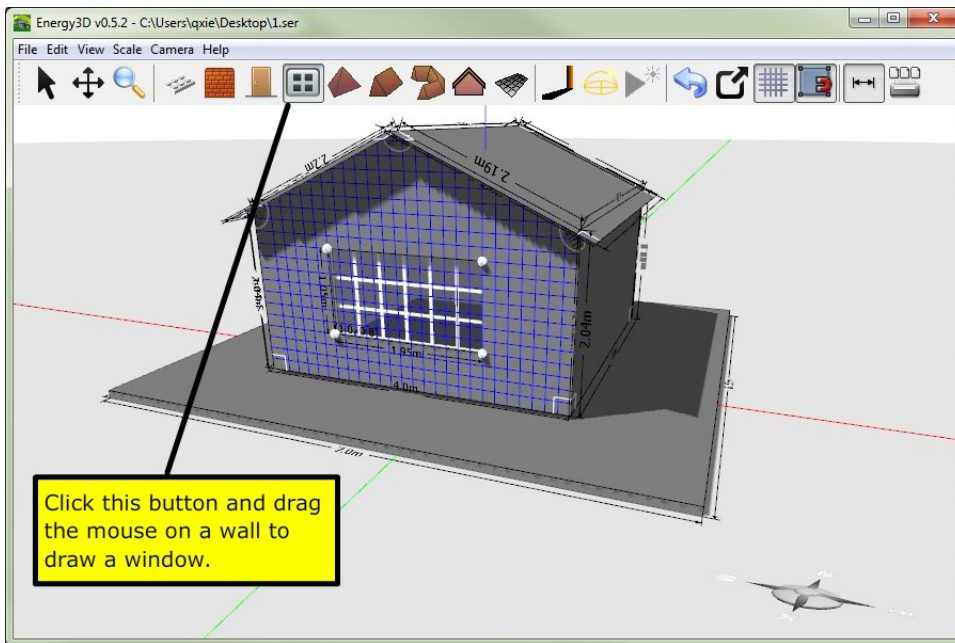

12. Save your design as "design-1A-*teamname*" on your USB stick.

# Evaluation of Design #1

1. Open the Heliodon tool. Set it to your latitude. Turn on the Shadows tool right next to it.

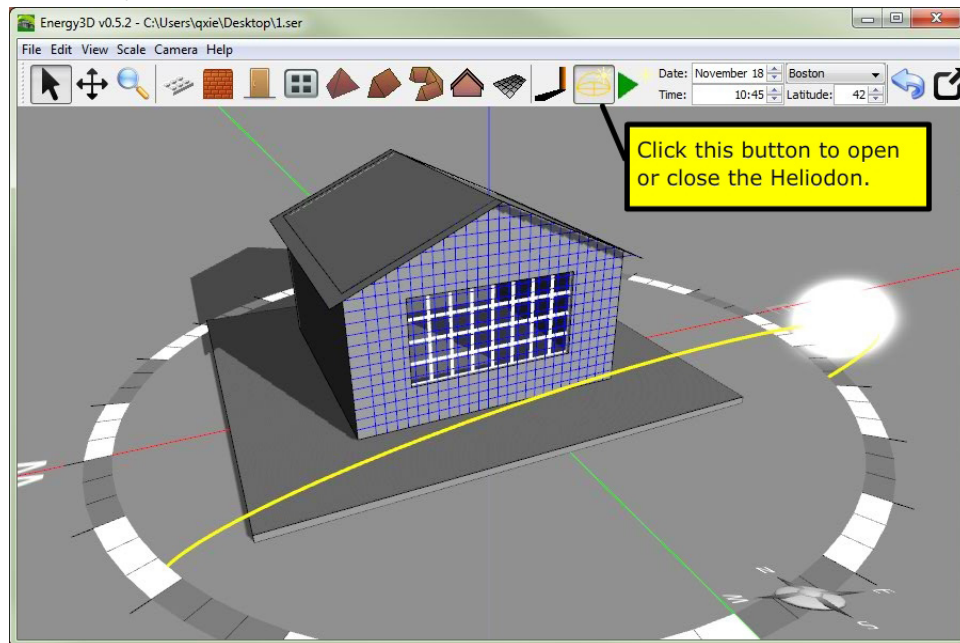

2. Study how sunlight enters your house at different times of day and different times of year. Do you think your windows are effective passive solar collectors? Explain.

3. Zoom inside your house. Study the path of sunlight from your various windows. Do you think this would be a comfortable room on a sunny day? Explain.

4. Now step back and consider as a team how well Design #1 meets your goals. Here is a checklist.

- The house has features that you think will make it energy efficient.
- The house is attractive and has “curb appeal”.
- The interior would be comfortable to be in on a sunny day or a cold night.
- The house is not larger than the 28 x 36 cm platform provided in the software.
- To make room for the heater light bulb, the walls must be at least 20 cm high and you can cut a 12 cm diameter hole in the center of the floor.
- The house is buildable – that is, not too complex and not too many pieces.
- The minimum window area is 50 cm<sup>2</sup>.

Describe how Design #1 successfully met these goals.

Describe how Design #1 was not successful.

5. Based on your review, modify your design and save it again as a new file “design-1B-teamname” on your USB stick.

## Design #2

1. Now that you have some experience with Energy3D, try another altogether different design. **Give another member of your team a turn running the computer.**
2. Close and re-open Energy3D. Design a new house from scratch.
3. Save your design as "design-2A-teamname" on your USB stick.

# Evaluation of Design #2

1. Open the Heliodon tool. Set it to your latitude. Turn on the Shadows tool.
2. Study how sunlight enters your house at different times of day and different times of year. Examine the house both from the outside and the inside.
3. Step back and consider how well Design #2 meets your goals. Refer back to your checklist.

Describe how Design #2 successfully met these goals.

Describe how Design #2 was not successful.

4. Based on your review, modify your design and save it again as a new file "design-2B-teamname" on your USB stick.

## Design #3

1. Try to come up with one more altogether different design. Give another member of your team a turn running the computer.
2. Close and re-open Energy3D. Design a new house from scratch.
3. Save your design as "design-3A-*teamname*" on your USB stick.

## Evaluation of Design #3

1. Open the Heliodon tool. Set it to your latitude. Turn on the Shadows tool.
2. Study how sunlight enters your house at different times of day and different times of year. Examine the house both from the outside and the inside.
3. Step back and consider how well Design #3 meets your goals. Refer back to your checklist.

Describe how Design #3 successfully met these goals.

Describe how Design #3 was not successful.

4. Based on your review, modify your design and save it again as a new file "design-3B-teamname" on your USB stick.

## Select your best design

You now have three designs to choose from. Each one may have features that you like or dislike. Review the design goals and select one of them for building and testing. To help you choose, fill out the rating chart below. 3=excellent, 2=good, 1=fair, 0=bad

Results			
Goal	House #1	House #2	House #3
Energy efficiency			
Ease of building			
Attractiveness			
Shape			
Simplicity			
Size			
Comfort			

Which design will you select?

Explain why you selected the design that you did.

# Print your design

1. View the print preview, which displays the house and all of its pieces as they will be printed on regular-size paper.

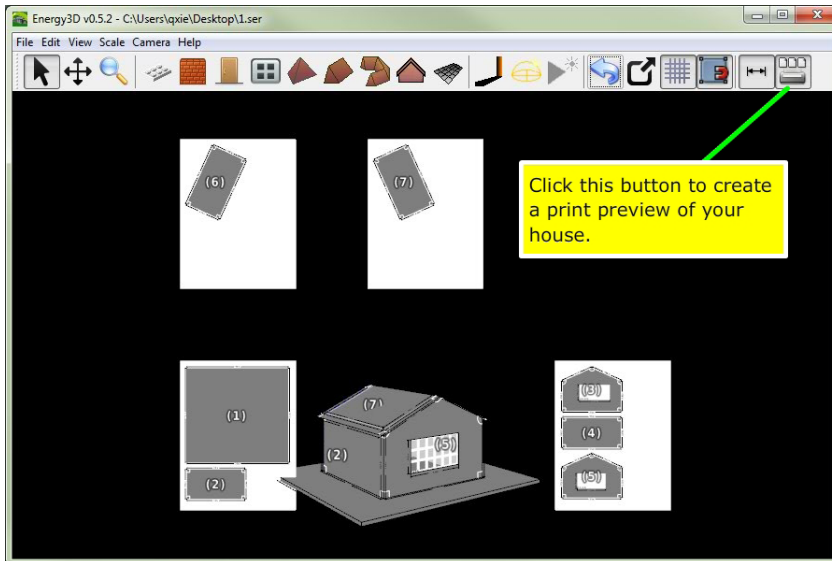

2. You can zoom into a sheet and see the dimensions of each piece.

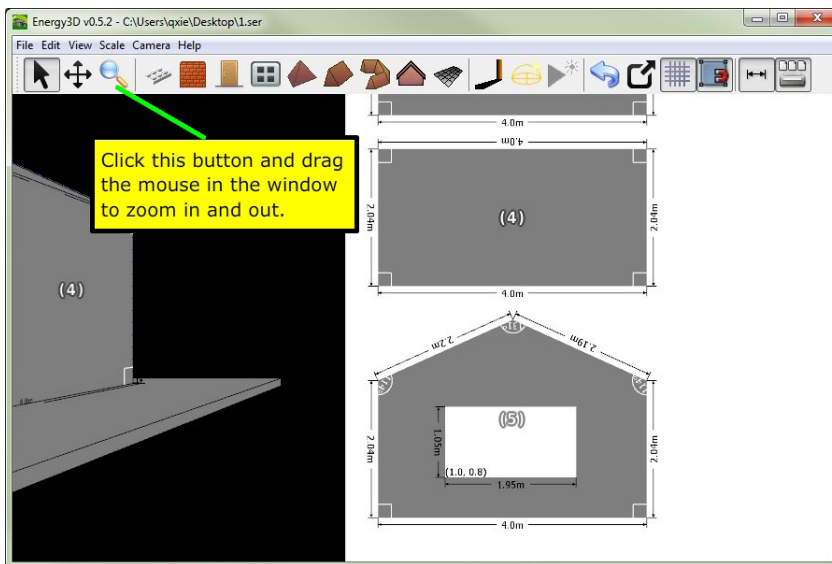

3. Print all of the pieces.

# Scale up your house

1. Display your house in "print view." Note that the dimensions and angles for every piece are shown. Use your printed pieces for guidance.
2. Transfer each piece to cardstock, using a ruler and a protractor to copy the lengths and angles. To be as efficient in your use of the cardstock as possible, plan out your pieces in advance. Here are four steps for scaling up a triangle.

Step 1

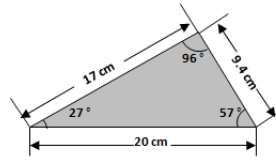

Cardstock sheet

Use a ruler and a pencil to draw a line that is 20 cm long.

A diagram showing a ruler placed on a cardstock sheet. A pencil is shown drawing a horizontal line that is 20 cm long, as indicated by a dimension line above the line.

Step 2

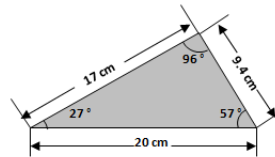

1. Anchor the center of the protractor at this endpoint of the line.

2. Rotate the swinging arm of the protractor to 57°. Draw a cross sign right at the pointer of the arm.

20 cm

A diagram showing a ruler and a protractor being used to draw a 20 cm line on a cardstock sheet. The ruler is placed horizontally, and a pencil is shown drawing a horizontal line that is 20 cm long. A protractor is placed at the right endpoint of the line, with its center anchored at that point. The swinging arm of the protractor is rotated to 57°, and a cross sign is drawn at the pointer of the arm.

Step 3

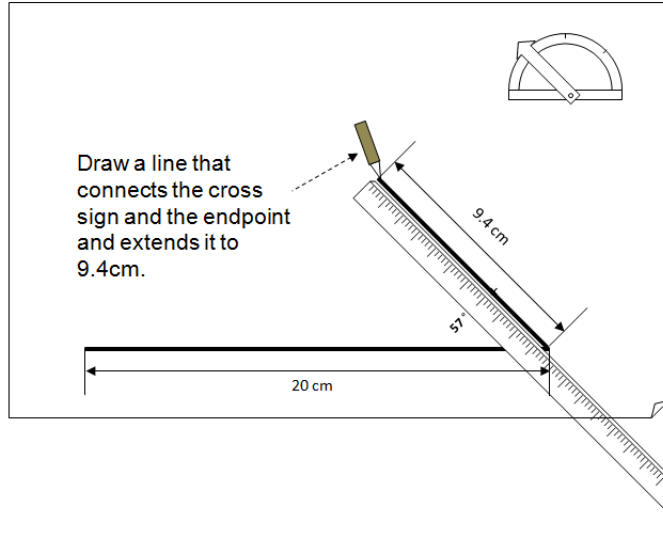
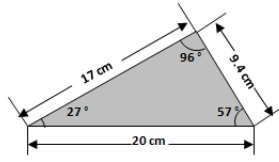

Step 4

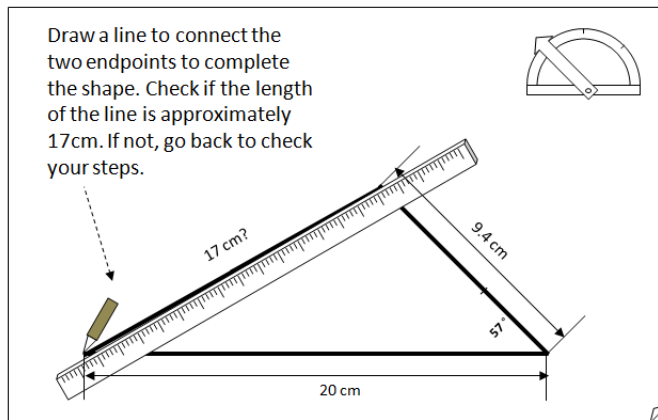
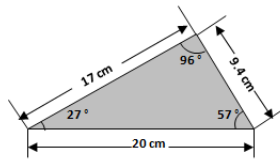

3. The same steps work for more complex shapes.

Other shapes

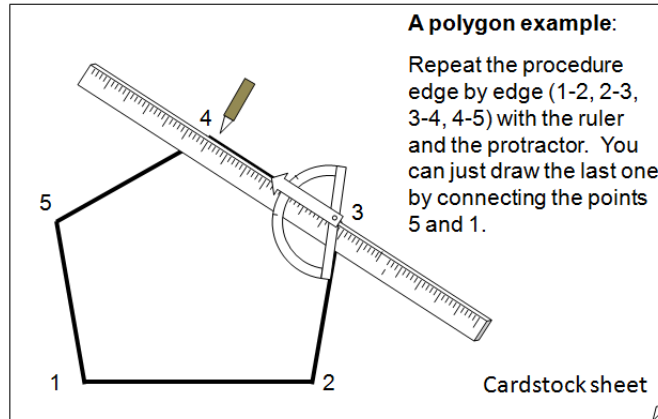

4. Remember to mark the windows as well as the outline of each piece.

# Construction

1. Cut out the cardstock pieces with scissors.
2. Make a hole in one wall for the temperature sensor 10 cm above the floor. Pick the wall that is farthest from the heater light bulb. The sensor will go 3 cm into the house and it must be at least 5 cm from the heater light bulb.
3. Cut out the window openings with scissors or a utility knife and tape pieces of acetate over them on the inside.
4. Cut a circle in the floor (12 cm diameter, the size of a CD) for the heater light bulb.
5. Write your team name and your team member names on the house.
6. Tape the scaled up cardstock house pieces together. Use the 3D house view in "print view" as a guide.
7. Tape the floor to the house walls.
8. Calculate the total floor area and window area of your house. Also calculate the window area that faces south. Your measurements can be rounded to the nearest centimeter. Fill out the table below. The measurements for the standard house are included for comparison.

---

---

	Own House <b>105</b>
--	----------------------

---

	Standard house	Your house
Floor area (cm <sup>2</sup> )	16x24=384	
Window area (cm <sup>2</sup> )	10x12=120	
Window/floor ratio	120/384 = .31	
South-facing window area (cm <sup>2</sup> )	120	
South window/floor ratio	.31	

## House heating test

Your goal in testing your house is to measure how much power it takes to keep your house 10 °C warmer than the air around it. This is the same test you used with the standard house.

### Collect data

1. Connect the temperature sensor to your computer. Use one temperature sensor.
2. Open the Logger Lite file that goes with this experiment: *own house stay warm.gmbl*
3. Measure the room temperature. We will assume it stays reasonably constant throughout the experiment. Record temperature in the table below.
4. Calculate your target temperature: 10 °C above room temperature. Record your room and target temperature in the table below.
5. Insert the temperature sensor in the hole you made in the house. It must be pushed through the wall, so that it is 3 cm from the wall. Use the same 3x3 cm cardstock sensor holder you used in Chapter 1.
6. Turn the heater on.
7. Start collecting data when the sensor is a few degrees below the target temperature.
8. When the sensor reaches 0.2 °C above the target temperature, switch the heater OFF and record the time in the table below (A).
9. When the sensor drops to 0.2 °C below the target temperature, switch the heater ON and record the time in the table below (B).
10. When the sensor again reaches 0.2 °C above the target temperature, switch the heater OFF and record the time in the table below (C).
11. Stop collecting data.
12. Click the "scale" icon to fit the graph to your data.
13. Save the LoggerLite data file.
14. Calculate the average power requirement to keep the house warm by filling out the rest of the table below.

House heating test	
Room temperature: _____ °C	
Target temperature: _____ °C	
Upper limit (target temperature + 0.2): _____ °C	
Lower limit (target temperature - 0.2): _____ °C	
Event	Time (from data table)
A. Turn heater OFF at upper limit	
B. Turn heater ON at lower limit	
C. Turn heater OFF at upper limit	
D. Total cycle time (C - A)	
E. Total time ON (C - B)	
F. proportion of time the heater is on (C - B) / (C - A)	
G. Average power requirement (40 watts * the proportion of time the heater is on)	_____ W

### *Results*

How did this house perform compared to your standard house?

**Feature:** What specific features of your design contributed to or detracted from the energy performance of the house?

**Results:** What evidence do you have from the test to support your claim?

**Modification:** Based on your results what design changes would you propose to improve the performance of these design features?

Your teacher will make a summary chart of the performance of each team's house. How did your house perform compared to other teams?

What did you learn from other teams' designs that could help you improve your house?

# Solar heating test

First you tested your house using a heater light bulb. That situation mirrors nighttime when there is no solar radiation.

Now you will heat your house using the heater light bulb inside and a very bright light bulb outside as the "sun." You will turn the heater on and off, but leave the sun on all the time. This will mirror sunny daytime winter conditions, when sunshine reduces the amount of heat a furnace must supply.

## Collect data

1. Connect the temperature sensor to your computer.
2. Open the Logger Lite file that goes with this experiment:  
*own house solar heating.gmbl*
3. Assume that room temperature has not changed. Calculate the target temperature (room temp + 10 °C) and enter it in the table below.
4. Set up the gooseneck lamp with a 300 W bulb in it, due south of the building. The tip of the bulb should be 20 cm from the house window and aimed downward at about a 35° angle, as if it were noon in winter. Use the template provided by the teacher to position the sun.

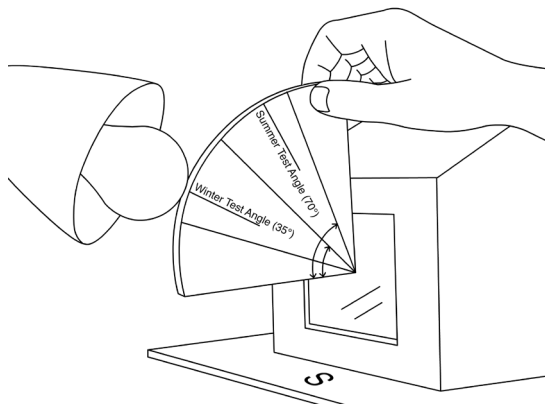

5. Switch the heater light bulb and the sun light bulb on.

*NOTE: The bulb is very hot. Be careful not to touch it, and wait until it cools down to move or store it. Turn it off except while doing the experiment.*

6. Start collecting data when the sensor is a few degrees below the target temperature.
7. When the upper sensor reaches 0.2 °C above the target temperature, switch the heater OFF and record the time in the table below (A). Leave the sun on.
8. When the upper sensor reaches 0.2 °C below the target temperature, turn the heater ON. Record the time in the table below (B).
9. When the sensor again reaches 0.2 °C above the target temperature, switch the heater OFF and record the time in the table below (C).
10. Stop collecting data.
11. Click the "scale" icon to fit the graph to your data.
12. Save the LoggerLite data file.
13. Print your LoggerLite graph and make a copy for each team member to put in their workbook.
14. Calculate the average power requirement to keep the house warm by filling out the rest of the table.

### Solar heating test

Room temperature: \_\_\_\_\_ °C

Target temperature: \_\_\_\_\_ °C

Upper limit (target temperature + 0.2): \_\_\_\_\_ °C

Lower limit (target temperature – 0.2): \_\_\_\_\_ °C

Event	Time (from data table)
A. Turn heater OFF at upper limit	
B. Turn heater ON at lower limit	
C. Turn heater OFF at upper limit	
D. Total cycle time (C - A)	
E. Total time ON (C - B)	
F. Proportion of time the heater is on (C - B) / (C - A)	
G. Average power requirement (40 watts * proportion of time heater is on)	_____ W
H. Power requirement without sun	_____ W
I. Solar contribution	_____ W

## Results

How did this solar-heated house perform compared to the house without sunlight?

How did your house performance compare to other teams?

**Feature:** What specific features of your design contributed to or detracted from its performance as a passive solar house?

**Results:** What evidence do you have from the test to support your claim?

**Modification:** Based on your results what design changes would you make to improve its performance?

### Instructions

1. Make a claim. Answer the first question with one or two sentences only.
2. For the second question, use evidence, data, examples, results, or descriptions from your experiment(s) and/or model-based activity.
3. For the third question, apply what you learned from your experiment and model-based activities to support the claim you made.

Claim: What are the advantages and disadvantages of having large south-facing windows?

Evidence: What did your experiments reveal about passive solar heating? (You can include experiments from Chapter 2 as well as Chapter 3.)

Reasoning: How do the results of your experiments explain your claim above?

# Chapter 4: Modify Your House

## Introduction

Now that you have tested your own energy-efficient house design, it's time to modify it and make it work better. A cycle of design, testing, redesign and retesting is an essential part of engineering.

Your success will be measured using the same tests as before:

- keeping the house warm with a heater light bulb (the “no sun” condition)
- reducing the heating requirement using sunshine from a low angle (the “winter sunshine” condition)

You can add other materials from what's available, and also change the design — whatever you think would improve the performance of the house. You can also add “additions” on the outside if you think they will help — solar greenhouses, for example.

Every change *must have a design rationale*, including your theory for why it will help, based on the scientific ideas from the Heat Transfer chapter.

To make your engineering process more systematic, you will be asked to tackle one improvement at a time and measure the effect of that improvement. You will also be asked to do some specific investigations before making your design changes.

---

How much can you improve the energy performance of your house?

---

## Tools & materials

- Two temperature sensors
- Computer
- Small square of cardboard (5x5 cm)
- Tape
- One 40 W heater light bulb
- Metal ruler
- Logger Lite
- Your house

## Explore convection

Often the most valuable first step in making a house energy efficient is to stop air from leaking in and out. Cold air entering and hot air escaping is a large source of heat loss, in both older and newer construction.

You will conduct a series of experiments to explore convection (the motion of air) in your house and then see how much you can improve its performance.

## Procedure & data collection

1. Tape one sensor into the hole in the standard house at 10 cm. This will be your fixed monitoring temperature sensor.
2. Make a series of holes in the end wall opposite the monitoring sensor every 5 cm above the bottom of the house. Use a sharp pen or pencil. The holes should be just large enough so that the movable temperature sensors can be inserted into the house.

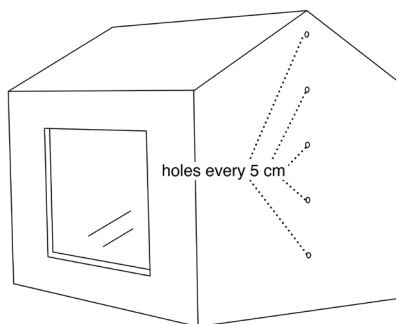

3. Tape the other sensor to a small piece of cardboard (about 5x5 cm) with a bend in the wire so that the end sticks up about 3 cm. This will be your movable temperature sensor.

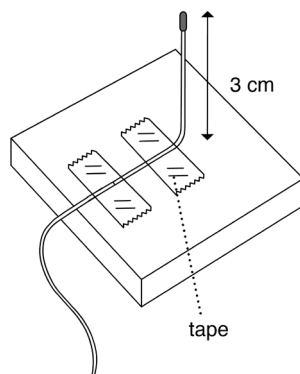

4. Open the Logger Lite file that goes with this experiment:  
*house convection.gmbl*
5. Start collecting data. Record the initial temperature in the table below.
6. Turn the heater on. Let the temperature of the fixed sensor rise until the inside is 10 °C above the initial temperature.
7. Have one team member take responsibility for keeping the reading of the fixed sensor within 0.2 °C or less of the target temperature. Turn the heater off and on to maintain a constant temperature for the fixed sensor.
8. Have another team member measure the temperature at each height by inserting the movable sensor into each hole in turn, from 5 cm to 25 cm, and then back down again.

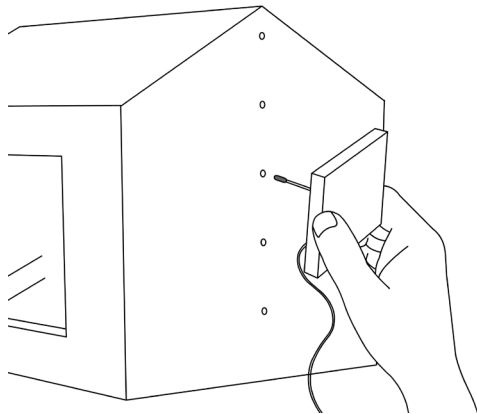

9. You must wait in each hole long enough for the temperature to approach a settled value – about 30 seconds. It's OK not to wait for the exact settled value. The graph will look something like this:

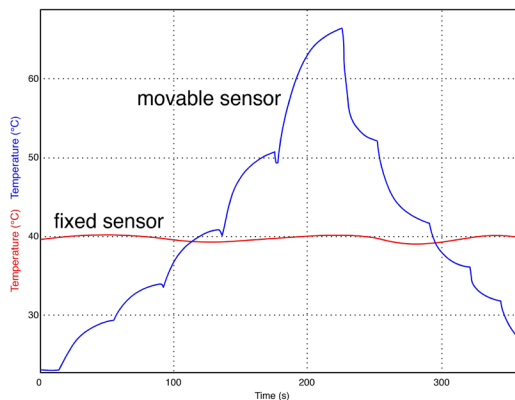

10. Record the temperature values at the different heights in the table below.

11. Calculate the average temperature for each height.

Temperature at different heights			
Initial temperature: _____ °C Target inside temperature: _____ °C (Initial + 10 °C)			
Height (cm)	Temperature (going up)	Temperature (going down)	Average of two temperatures
5			
10			
15			
20			
25			

## Results

What is the maximum temperature difference from bottom to top?

What is the difference between the fixed monitoring sensor and the highest temperature?

## Analysis

If the fixed sensor shows a constant temperature, explain what creates the observed temperature pattern seen in the graph of the other sensors.

## Tools & materials

- Two temperature sensors
- Computer
- Small square of foamcore or cardboard (5 x 5 cm)
- Tape
- Scissors
- One 40 W heater light bulb
- Your house

## Convection in a leaky house (optional)

### Procedure & data collection

You probably measured a strong stratification (layering) of temperature in the previous experiment. What if there were leaks in a house so that air could escape from the attic?

1. Maintain the identical setup as in Experiment 2, with one fixed monitor sensor and one movable sensor attached to a small piece of foamcore or cardboard.
2. Cut a hole in the roof of the house about 1 x 10 cm. Leave the flap attached, so you can easily close the hole with a piece of tape.

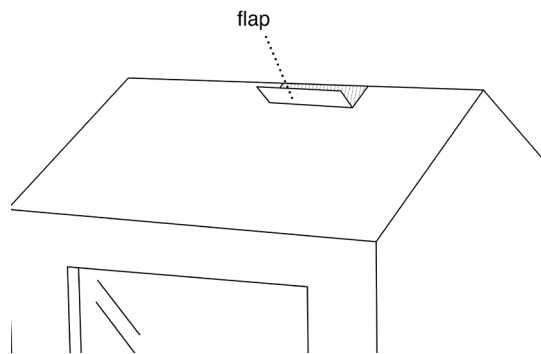

3. Open the Logger Lite file that goes with this experiment: *leaky house.gmbl*
4. Start collecting data. Record the initial temperature in the table below.
5. Turn on the heater. Let the temperature of the fixed sensor rise until it is 10 °C above the initial temperature.

6. Have one team member take responsibility for keeping the reading of the fixed sensor within 0.2 °C or less of the target temperature. Turn the heater off and on to maintain a constant temperature for the fixed sensor.
7. Have another team member measure the temperature at each height by inserting the movable sensor into each hole in turn. You don't need to go back down again – one measurement at each height will be close enough. You must wait in each hole long enough for the temperature to approach a settled value – about 30 seconds. It's OK not to wait for the exact settled value. You will have a graph much like the one shown in the previous experiment.
8. Record the temperature values at the different heights in the table below.

Temperature with hole in the roof		
Initial temperature: _____ °C		
Target inside temperature: _____ °C		
Height (cm)	Temperature with hole in roof	Temperature without hole in roof
5		
10		
15		
20		
25		

## Results

What is the maximum temperature difference from bottom to top when the hole is open?

What is the difference between the fixed monitoring sensor and the highest temperature when the hole is open?

How do these values compare to the house without a hole in the roof?

## Analysis

Describe how your results provide evidence for natural convection.

Describe how heat would flow if the hole were only near the floor.

## Seal up the cracks

Now that you've measured the effect of big leaks, tighten up your house, seal all the cracks, and see what effect it has.

Tape shut the openings that you made in the previous experiment.

Tape shut any other cracks or leaks that you can find in your model.

Use the same test as before to measure how much power it takes to keep your house 10 °C warmer than the air around it.

### Collect data

1. Connect the temperature sensor to your computer. Use one temperature sensor.
2. Open the Logger Lite file:  
*seal up house.gmbl*
3. Measure the room temperature. Record it in the table below.
4. Calculate your target temperature, 10 °C above room temperature, and record it in the table below.
5. Install the sensor in the standard monitoring position, through a hole in the wall 10 cm up and 3 cm into the house.
6. Turn the heater on.
7. When the sensor reaches 0.2 °C above the target temperature, switch the heater OFF and record the time in the table below (A).
8. When the sensor drops to 0.2 °C below the target temperature, switch the heater ON and record the time in the table below (B).
9. When the sensor again reaches 0.2 °C above the target temperature, switch the heater OFF and record the time in the table below (C).
10. Stop collecting data.
11. Click the "scale" icon to fit the graph to your data.
12. Save the LoggerLite data file.
13. Calculate the average power requirement to keep the house warm by filling out the rest of the table below.

House heating test	
Room temperature: _____ °C	
Target temperature (room temperature + 10): _____ °C	
Upper limit (target temperature + 0.2): _____ °C	
Lower limit (target temperature – 0.2): _____ °C	
Event	Time (from data table)
A. Turn heater OFF at upper limit	
B. Turn heater ON at lower limit	
C. Turn heater OFF at upper limit	
D. Total cycle time (C - A)	
E. Total time ON (C - B)	
F. proportion of time the heater is on (C - B) / (C - A)	
G. Average power requirement (40 watts * proportion of time heater is on)	_____ W

Comparisons	
Condition	Power requirement
Standard house (ch. 1)	
Your model house (ch. 3)	
Your model house with holes top and bottom (this section)	
Your model house with all leaks sealed	

## Cut down convection with a ceiling

Now try adding a ceiling in the house and see how the pattern of temperature distribution will change.

### Construction

1. Maintain the identical setup as in the “Explore convection” experiment, with one fixed monitor sensor and one movable sensor attached to a small piece of foamcore or cardboard.
2. Trace the floor of the house on a piece of cardstock.
3. Cut out the rectangular piece that is the same shape and size.
4. Bend the piece a bit so that it can be pushed through the hole in the bottom of the house. Push it up to make a “ceiling” at the tops of the walls, which should be 20 cm high. It should stay roughly in place without tape, but you can add a few small pieces of tape if necessary.

### Data collection

1. Open the Logger Lite file that goes with this experiment: *convection with ceiling.gmbl*
2. Turn on the heater. Let the reading of the fixed sensor temperature rise until it is 10 °C above the initial temperature. Record in the table below.
3. Have one team member take responsibility for keeping the reading of the fixed sensor within 0.2 °C or less of the target temperature. Turn the heater off and on to maintain a constant temperature for the fixed sensor.
4. Start collecting data. Record the initial temperature in the table.
5. Have another team member measure the temperature at the heights of 5, 10, 15, and 20 cm by inserting the movable sensor into each hole in turn. Also measure the temperature in the “attic,” above the ceiling.
6. Save your Logger Lite file.
7. Compare your results with the previous experiments.

### Tools & materials

- Two temperature sensors
- Computer
- Cardstock of file folder card the size of the house (16 x 24 cm)
- Small square of foamcore or cardboard (5 x 5 cm)
- Tape
- One 40 W heater light bulb
- Scissors
- Your house

Temperature with ceiling		
Initial temperature: _____ °C Target inside temperature: _____ °C		
Height (cm)	Temperature with ceiling	Temperature without hole in roof, no ceiling
5		
10		
15		
20		

## Results

What is the maximum temperature difference from bottom to top when there is a ceiling?

What was the effect of the ceiling on temperatures?

Explain your observation in terms of natural convection.

### Instructions

1. Make a claim. Answer the first question with one or two sentences only.
2. For the second question, use evidence, data, examples, results, or descriptions from your experiment(s) and/or model-based activity.
3. For the third question, apply what you learned from your experiment and model-based activities to support the claim you made.

Claim: How do ceilings change the natural convection patterns in a house?

Evidence: What did your experiments show you about natural convection patterns? (You can include experiments from Chapter 2 as well as Chapter 3.)

Reasoning: How do the results of your experiments explain your claim above?

## House heating test with a ceiling added

Now test the improvement in overall performance when you add a ceiling. Use the same tests as before to measure how much power it takes to keep your house 10 °C warmer than the air around it.

### Collect data

1. Connect the temperature sensor to your computer. Use one temperature sensor.
2. Open the Logger Lite file:  
*own house with ceiling.gmbl*
3. Measure the room temperature. Record it in the table below.
4. Calculate your target temperature, 10 °C above room temperature, and record it in the table.
5. Install the sensor in the standard monitoring position, through a hole in the wall 10 cm up and 3 cm into the house.
6. Turn the heater on.
7. When the sensor reaches 0.2 °C above the target temperature, switch the heater OFF and record the time in the table below (A).
8. When the sensor drops to 0.2 °C below the target temperature, switch the heater ON and record the time in the table below (B).
9. When the sensor again reaches 0.2 °C above the target temperature, switch the heater OFF and record the time in the table below (C).
10. Stop collecting data.
11. Click the "scale" icon to fit the graph to your data.
12. Save the LoggerLite data file.
13. Calculate the average power requirement to keep the house warm by filling out the rest of the table below.

### House heating test with ceiling

Room temperature: _____ °C	
Target temperature (room temperature + 10): _____ °C	
Upper limit (target temperature + 0.2): _____ °C	
Lower limit (target temperature – 0.2): _____ °C	
Event	Time (from data table)
A. Turn heater OFF at upper limit	
B. Turn heater ON at lower limit	
C. Turn heater OFF at upper limit	
D. Total cycle time (C - A)	
E. Total time ON (C - B)	
F. proportion of time the heater is on (C - B) / (C - A)	
G. Average power requirement (40 watts * proportion of time heater is on)	_____ W

Compare your current house performance with previous experiments.

### Summary of results

Condition	Power requirement
Standard house (ch. 1)	
Your model house (ch. 3)	
Your model house with holes top and bottom (this section)	
All leaks sealed	
Ceiling added	

## Analysis

What specific features of your changes do you think contributed the most to energy efficiency?

Your teacher will make a summary chart of the performance of each team's house. Consider your house performance compared to other teams. Why do you think it did better or worse than other designs? Be specific and give scientific explanations.

**Feature:** What specific changes to the house contributed to stopping heat loss by convection?

**Results:** What evidence do you have from the above tests to support your claim?

**Modification:** Based on your results, what further design changes would you propose to stop heat loss by convection?

## Conductivity of the walls

Energy efficient houses are always very well insulated. Often some parts of the building envelope are insulated more than other parts

Here's a typical well-insulated wall. Each layer has a purpose. The vapor barrier stops moisture from migrating outward. The insulation slows heat flow. The continuous insulation blocks air circulation and thermal bridging through the wood, which is less insulating than the insulation around it. The outside air barrier stops infiltration.

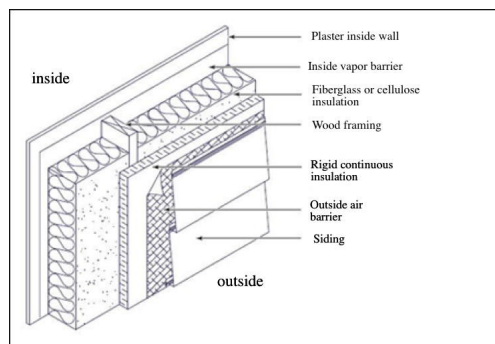

Air spaces inside walls may or may not add insulating value. If they are wider than about 2 cm, convection loops form and heat is easily transferred across them. If they are narrower than that, convective loops do not form and they provide insulating value.

Before you insulate your whole house, test the effect of various insulations and choose the one that seems to be the best.

## Tools & materials

- Two temperature sensors
- Computer
- Your house
- Squares of foamcore
- Acetate
- Masking tape and/or clear tape

## Procedure & data collection

1. Install one of the sensors in the standard monitoring position, through a hole in the wall 10 cm up and 3 cm into the house.
2. Draw a line around the entire house 10 cm up. You will test the outside surface temperature of the house at this height, as a way of measuring the insulating value of the walls and windows. The lower the outside surface temperature, the greater the insulating value of the material.

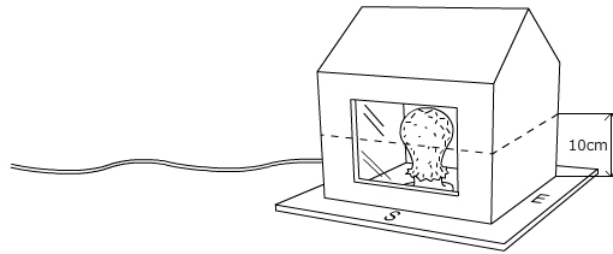

3. First, test the insulating value of the existing wall.
  - a. Tape the sensor to the outside of the wall along the 10 cm line, opposite the monitoring sensor.

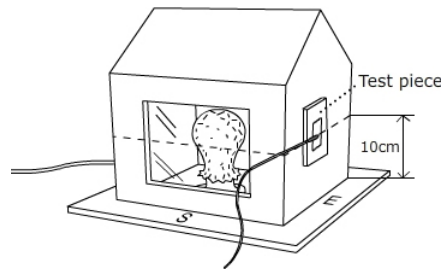

- b. Open the Logger Lite file that goes with this experiment: wall conduction.gmbl
  - c. Start collecting data. Note the initial temperature.
  - d. Turn on the heater light bulb. Let the temperature rise until the monitoring sensor is 10 °C above the initial temperature.
  - e. Turn off the heater. Record the monitoring and outside surface temperatures in the table below.
4. Repeat this measurement with the sensor taped to the outside of the acetate window. Record your results in the table.

- Prepare different sample wall insulations. Make test pieces that are 5 x 5 cm and tape them to the wall as shown below. Repeat the measurements with one layer of foamcore, then two layers of foamcore. You could try other materials if you wish. Record your results in the table.
- Construct a "double-glazed window" to test. First cut a 5 x 5 cm square out of the center of an 8 x 8 cm piece of foam core. This will be your spacer.

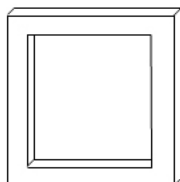

- Tape the spacer to the house window, tape an 8 x 8 cm square of acetate to the outside of the spacer, and tape the sensor to the outside of the acetate, as shown below.

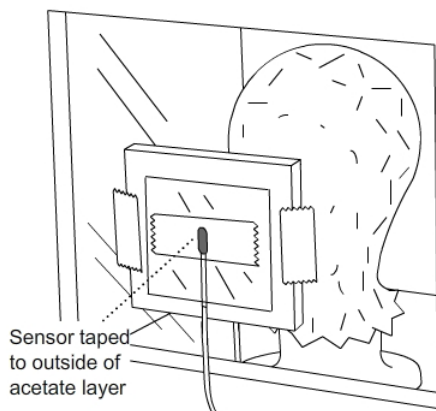

- Repeat the measurement and record your result in the table.
- Save the LoggerLite data file.

Conductivity of walls	
Wall construction	Outside surface temperature
Cardstock	
Acetate	
Cardstock plus one layer foamcore	
Cardstock plus two layers foamcore	
Acetate two layers (with airspace)	

## *Analysis*

Which wall arrangement had the lowest conductivity?

What is your evidence?

### Instructions

1. Make a claim. Answer the first question with one or two sentences only.
2. For the second question, use evidence, data, examples, results, or descriptions from your experiment(s) and/or model-based activity.
3. For the third question, apply what you learned from your experiment and model-based activities to support the claim you made.

**Claim:** Describe how materials and thickness of materials affect heat flow into a house on a hot day.

**Evidence:** What did your experiments show you about the effect of thickness and materials on heat flow? (You can include experiments from Chapter 2 as well as Chapter 3.)

**Reasoning:** How do the results of your experiments explain your claim above?

## Reduce heat loss with insulation

Based on your experiments, decide how you will insulate the walls of your house. You may draw from the following materials:

- ½ sheet foamcore
- 2 sheets acetate

Here are the rules:

Only use materials that are equally available to all of the teams, unless your teacher decides otherwise.

When possible, apply insulation to the outside of the existing shell, so that the interior volume remains about the same.

Do not place any material closer than 5 cm from the light bulb heater.

Modify your existing shell rather than starting over, unless you have a strong engineering reason to change the shell and your teacher gives specific permission.

After you have insulated your house, test its performance.

### Collect data

1. Connect the temperature sensor to your computer. Use one temperature sensor.
2. Open the Logger Lite file:  
*insulated house keep warm.gmbl*
3. Measure the room temperature. Record it in the table below.
4. Calculate your target temperature, 10 °C above room temperature, and record it in the table below.
5. Install the sensor in the standard monitoring position, through a hole in the wall 10 cm up and 3 cm into the house.
6. Turn the heater on.

7. When the sensor reaches 0.2 °C above the target temperature, switch the heater OFF and record the time in the table (A).
8. When the sensor drops to 0.2 °C below the target temperature, switch the heater ON and record the time in the table (B).
9. When the sensor again reaches 0.2 °C above the target temperature, switch the heater OFF and record the time in the table (C).
10. Stop collecting data.
11. Click the "scale" icon to fit the graph to your data.
12. Save the LoggerLite data file.
13. Calculate the average power requirement to keep the house warm by filling out the rest of the table below.

House heating test	
Room temperature: _____ °C	
Target temperature (room temperature + 10): _____ °C	
Upper limit (target temperature + 0.2): _____ °C	
Lower limit (target temperature - 0.2): _____ °C	
Event	Time (from data table)
A. Turn heater OFF at upper limit	
B. Turn heater ON at lower limit	
C. Turn heater OFF at upper limit	
D. Total cycle time (C - A)	
E. Total time ON (C - B)	
F. proportion of time the heater is on (C - B) / (C - A)	
G. Average power requirement (40 watts * proportion of time heater is on)	_____ W

**Feature:** Did the wall materials affect the performance of the house?

**Results:** What evidence do you have from the test to support your claim?

**Modification:** Based on your results, what design changes in wall construction would you propose to improve performance even more?

## Sunspace addition

Sunspace, sunrooms, or greenhouses can be used to collect sunshine for heating. They are also pleasant spaces in the winter, although they have drawbacks as well. Build a sunspace addition to your house. Explore the temperatures in it and how it affects your house heating requirement.

### Construction

Build a sunspace addition, following these guidelines:

- You can use acetate, cardstock, and tape.
- The house should form one wall of the sunspace. That is, the sunspace should be against the house.
- The sunspace can be on any side of the house, but remember that your goal is for it to gain solar heating in the winter.
- The sunspace floor area should be **one-half the area of the house or smaller**.
- The sunspace should be loosely attached to the house leaving a crack where the sensor can be slid into the sunspace.

---

What are the temperatures in a sunspace?

---

Can a sunspace contribute heating energy to a house?

---

### Collect data

1. Place one sensor in the house at the standard position, 10 cm up and 3 cm in.
2. Place the other sensor in the sunspace about 10 cm up and near the wall of the house.
3. Tape a piece of paper on the outside of the sunspace so that it casts a shadow on the sunspace sensor. This will make sure the sensor measures the air temperature and is not heated directly by radiation.
4. Open the Logger Lite file that goes with this experiment:  
*sunspace test.gmbl*
5. Start collecting data. Turn on both the heater light bulb and the sun light bulb. Heat up the house to about 10 °C above room temperature – about 32 °C. This will be your house target temperature.
6. Keep the house within 0.2 °C of the target temperature by turning both the heating bulb and the sun bulb on and off. Observe at least two on-off cycles.
7. Scale the data with the “scale” button.
8. Save your data.

## Results

Describe the two graphs – inside the house and inside the sunspace. How are they the same and different?

## Analysis

How could you explain the differences?

## Solar heating contribution from the sunspace

How much can a sunspace contribute to the heating of a house? Explore this question using the standard Solar Heating Test.

Your design must accomplish two things:

- The sun light bulb must heat up the sunspace.
- The heat must be transported into the house.

Repeat the test several times as you refine the sunspace. Note that three tables have been provided. Describe your experimental conditions in each case. As a minimum, test the following conditions:

- Connect the sunspace to the house with cutout openings, so the heat can flow from the sunspace to the house.
- Add black paper inside the sunspace to increase solar absorption.

### Collect data

1. Connect the temperature sensor to your computer. Use one temperature sensor in the standard monitoring position.
2. Open the Logger Lite file:  
*own house with sunspace.gmbl*
3. Measure the room temperature. Record it in the table below.
4. Calculate your target temperature, 10 °C above room temperature, and record it in the table below.
5. Turn on both the heater light bulb and the sun light bulb.
6. When the sensor reaches 0.2 °C above the target temperature, switch the heater OFF and record the time in the table below (A).
7. When the sensor drops to 0.2 °C below the target temperature, switch the heater ON and record the time in the table below (B).

8. When the sensor again reaches 0.2 °C above the target temperature, switch the heater OFF and record the time in the table below (C).
9. Stop collecting data.
10. Click the "scale" icon to fit the graph to your data.
11. Save the LoggerLite data file.
12. Calculate the average power requirement to keep the house warm by filling out the rest of the table below.

House heating test with sunspace #1	
Room temperature: _____ °C	
Target temperature (room temperature + 10): _____ °C	
Upper limit (target temperature + 0.2): _____ °C	
Lower limit (target temperature - 0.2): _____ °C	
Event	Time (from data table)
A. Turn heater OFF at upper limit	
B. Turn heater ON at lower limit	
C. Turn heater OFF at upper limit	
D. Total cycle time (C - A)	
E. Total time ON (C - B)	
F. proportion of time the heater is on (C - B) / (C - A)	
G. Average power requirement (40 watts * proportion of time heater is on)	_____ W

### House heating test with sunspace #2

Room temperature: _____ °C	
Target temperature (room temperature + 10): _____ °C	
Upper limit (target temperature + 0.2): _____ °C	
Lower limit (target temperature – 0.2): _____ °C	
Event	Time (from data table)
A. Turn heater OFF at upper limit	
B. Turn heater ON at lower limit	
C. Turn heater OFF at upper limit	
D. Total cycle time (C - A)	
E. Total time ON (C - B)	
F. proportion of time the heater is on (C - B) / (C - A)	
G. Average power requirement (40 watts * proportion of time heater is on)	_____ W

### House heating test with sunspace #3

Room temperature: _____ °C	
Target temperature (room temperature + 10): _____ °C	
Upper limit (target temperature + 0.2): _____ °C	
Lower limit (target temperature – 0.2): _____ °C	
Event	Time (from data table)
A. Turn heater OFF at upper limit	
B. Turn heater ON at lower limit	
C. Turn heater OFF at upper limit	
D. Total cycle time (C - A)	
E. Total time ON (C - B)	
F. proportion of time the heater is on (C - B) / (C - A)	
G. Average power requirement (40 watts * proportion of time heater is on)	_____ W

### Summary of results

Description of experiment	Power requirement
Before sunspace is added – no sun (see previous experiment)	
Sunspace added	
Black paper added	

### Instructions

1. Make a claim. Answer the first question with one or two sentences only.
2. For the second question, use evidence, data, examples, results, or descriptions from your experiment(s) and/or model-based activity.
3. For the third question, apply what you learned from your experiment and model-based activities to support the claim you made.

Claim: What is a key design feature of a sunspace that helps it contribute to heating a home?

Evidence: What did your experiments show you about how a sunspace contributes to the heating of a house? (You can include experiments from Chapter 2 as well as Chapter 3.)

Reasoning: How do the results of your experiments explain your claim above?

# Connection to buildings

## Explore

What lessons or guidelines did you learn from these two tests that would apply to real buildings?

---

---

**150** Modify

Sunspace

---

# Chapter 5: Final Report

## *Introduction*

A new energy-efficient housing development is looking for a project engineer. The project engineer will be responsible for all design and construction decisions related to heating and cooling energy use. The project involves a variety of house designs that all need to be energy efficient.

This final report will be used to persuade a review committee that you have the understanding and inventiveness to apply what you have learned to the entire housing project.

Your project was a preliminary study to identify the most important features of an energy-efficient house. The committee will be looking at the energy performance of your model house as one indication of your skill. It will also look at the design ideas and materials you used to accomplish this. Equally important, however, you must demonstrate that you understand the science behind the energy-efficient designs and would be able to make further improvements and develop other designs.

Complete all of the sections below. If you write this on a computer, save your work on a USB memory stick.

Here is the outline of your report:

Summary

House performance: experimental data

Explanation of house performance and design choices

Heat flow analysis

Conclusion

## Energy-Efficient House Project: Final Report

Name:

Name of team:

Names of team members:

House dimensions

Floor area (cm<sup>2</sup>):

Total window area (cm<sup>2</sup>):

Total surface area (cm<sup>2</sup>):

### SUMMARY

Write a summary paragraph describing the house you designed, its special energy-efficient features, and what makes it a great energy-efficient house for this climate.

SUMMARY (cont.)

## HOUSE PERFORMANCE: EXPERIMENTAL DATA

Gather the results of your experimental data in the table below.

Summary of experimental data			
Winter heating	Power requirement (W)	Percentage of power requirement compared to the standard house*	Page reference
Standard house, no sun condition		= 100%	
Standard house, winter sun condition			
Own house, no sun condition			
Own house, winter sun condition			
Own house, with all modifications, no sun condition			
Own house, with all modifications, winter sun condition			

\* For example, if the standard house requires 20 W and "own house, no sun condition" requires 15 W, the percentage is  $15/20 = 75\%$ .

Did your modifications give you the improvement you expected?

Under what conditions did your house perform the best?

## EXPLANATION OF HOUSE PERFORMANCE AND DESIGN CHOICES

### House design

Describe the major features of your design (for example, the shape of the house, placement of windows, material choices). In each case, describe the feature, how it functions, and your evidence that it works that way. Use scientific explanations from the Heat Transfer unit to explain how each of these features affects energy efficiency. Refer to your experimental data to support your claims.

### Modifications

What did you learn from your experiments that guided your design choices? Explain what features were added after initial experiments, what features were modified, and how they affected the energy performance of the house. Include evidence from your experiments.

## HEAT FLOW ANALYSIS

Describe where and how heat is lost from your house and how different modifications changed the rate of heat loss. Use evidence from the Heat Transfer Basic units to describe the process.

Draw a picture of your house in vertical cross section, which is a slice through the center in the North-South direction. Label the wall, window, and roof materials. Label North and South.

On your drawing show your best guess for the temperature distribution throughout the house. Write down what you think are likely values of temperatures in various locations, assuming the outside temperature is 5 °C, the heater temperature is 40 °C, and the average temperature in the house is about 25 °C.

Draw arrows to show how you think heat flows around inside your house as well as in and out of your house.

## CONCLUSION

Given what you know now, if you were starting again from scratch and could make a completely different design, what materials and design features would you choose for your house? Why?



# Table of Contents

<b>Chapter 1: Build and Test a Standard House</b>	<b>1</b>
<hr/>	
• Building instructions	
• Warm up the house	
• Keep the house warm	
• Solar heating test	
<b>Chapter 2: Heat Transfer</b>	<b>27</b>
<hr/>	
Heat storage	29
Power and energy	35
Conduction	39
Convection	55
Radiation	67
Energy from the Sun	73
Energy Detective	81

## Chapter 3: Design and Build Your Own House 85

---

- Building instructions
- House heating test
- Solar heating test

## Chapter 4: Modify Your House 111

---

- Explore convection 112
- Conductivity of the walls 127
- Sunspace addition 135

## Chapter 5: Final Report 145

---

